

07.1-210 Replacing delivery valve seal - Turbodiesel

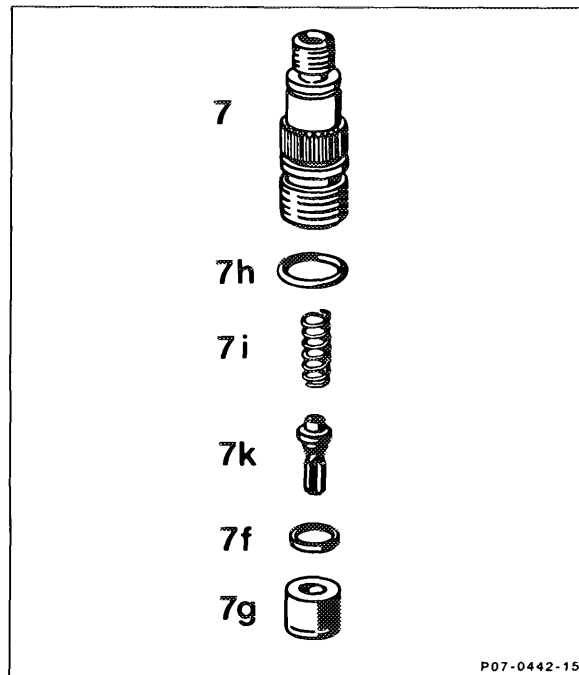

Delivery valve holder (7)	tightening torque 35 Nm, Special tool 617 589 01 09 00.
Compression spring (7i) copper seal (7f)	replace
Delivery valve (7k)	rinse in fuel before installing.
Delivery valve carrier (7g)	Make note of installed position.
O-ring (7h)	oil before assembling.

Special tool

