

Models 123 124 129 201

Special tools

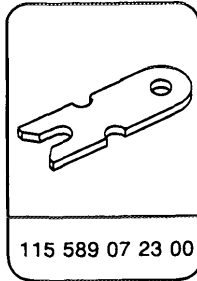

Insert slip gauge as far as possible between clutch housing and slave cylinder and note position of notches (arrow) in gauge.

If notches are not visible:
Clutch disk wear is acceptable.

If notches are visible:
Wear limit of disk has been reached.

Replace clutch disk.

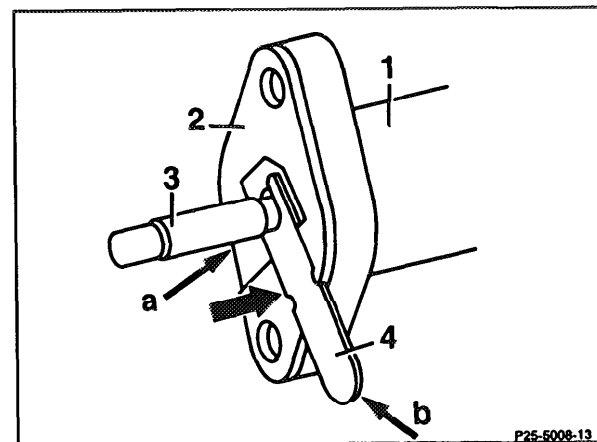
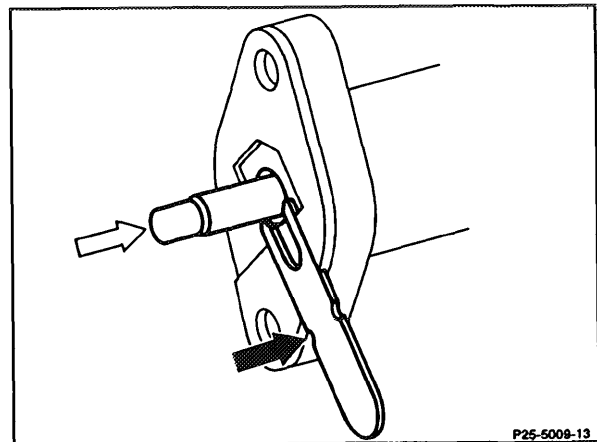

- 1 Slave cylinder
- 2 Shim between slave cylinder and clutch housing
- 3 Actuating rod
- 4 Slip gauge