

03-3190 Crankshaft machining dimensions and identifications

from 2015 onwards

Crankshaft machining dimensions and identifications, radial mounting ¹⁾

Machining stage ²⁾	Crankshaft bearing journal \varnothing	Colored identification on counterweight	Laser lettering on front of crankshaft
Standard	57.960-57.965	blue	B
Standard	57.955-57.960	yellow	G
Standard	57.950-57.955	red	R
Standard 1	57.945-57.950	white	W
Standard 1	57.940-57.945	purple	V
Rep. 1	57.705-57.715	-	-
Rep. 2	57.450-57.465	-	-
Rep. 3	57.205-57.215	-	-
Rep. 4	56.955-56.965	-	-

¹⁾ New crankshafts are identified before shipping from the factory with the tolerance classification of the crankshaft bearing journal \varnothing and fit bearing width either with a colored identification on the counterweights or with laser lettering on the front of the crankshaft journal.

²⁾ Standard size 1 and repair size crankshafts are not supplied as replacement parts except in reconditioned engines.

Crankshaft machining dimensions and identifications, axial mounting ¹⁾

Machining stage ²⁾	Fit bearing width ³⁾	Colored identification on counterweight 8 and 9	Laser lettering on front of crankshaft
Standard	24.530-24.533	none	0
Standard	24.500-24.533	none	0
Standard	24.500-24.533	none	0
Standard 1	24.600-24.633	red	1
Standard 2	24.600-24.633	red	1
Rep. 1	24.700-24.733	-	-
Rep. 2	24.900-24.933	-	-
Rep. 3	25.000-25.033	-	-
Rep. 4	-	-	-

- 2) New crankshafts are identified before shipping from the factory with the tolerance classification of the crankshaft bearing journal: \varnothing and fit bearing width either with a colored identification on the counterweights or with laser lettering on the front of the crankshaft journal.
- 3) Standard size 1 and repair size crankshafts are not supplied as replacement parts except in reconditioned engines
- 3) The thrust washers for axial bearing play are supplied in thicknesses of 2.15, 2.20, 2.25, 2.35 and 2.40 mm, each with a thrust washer for the crankcase and the thrustwasher for the bearing cap as a parts kit (2 in total)

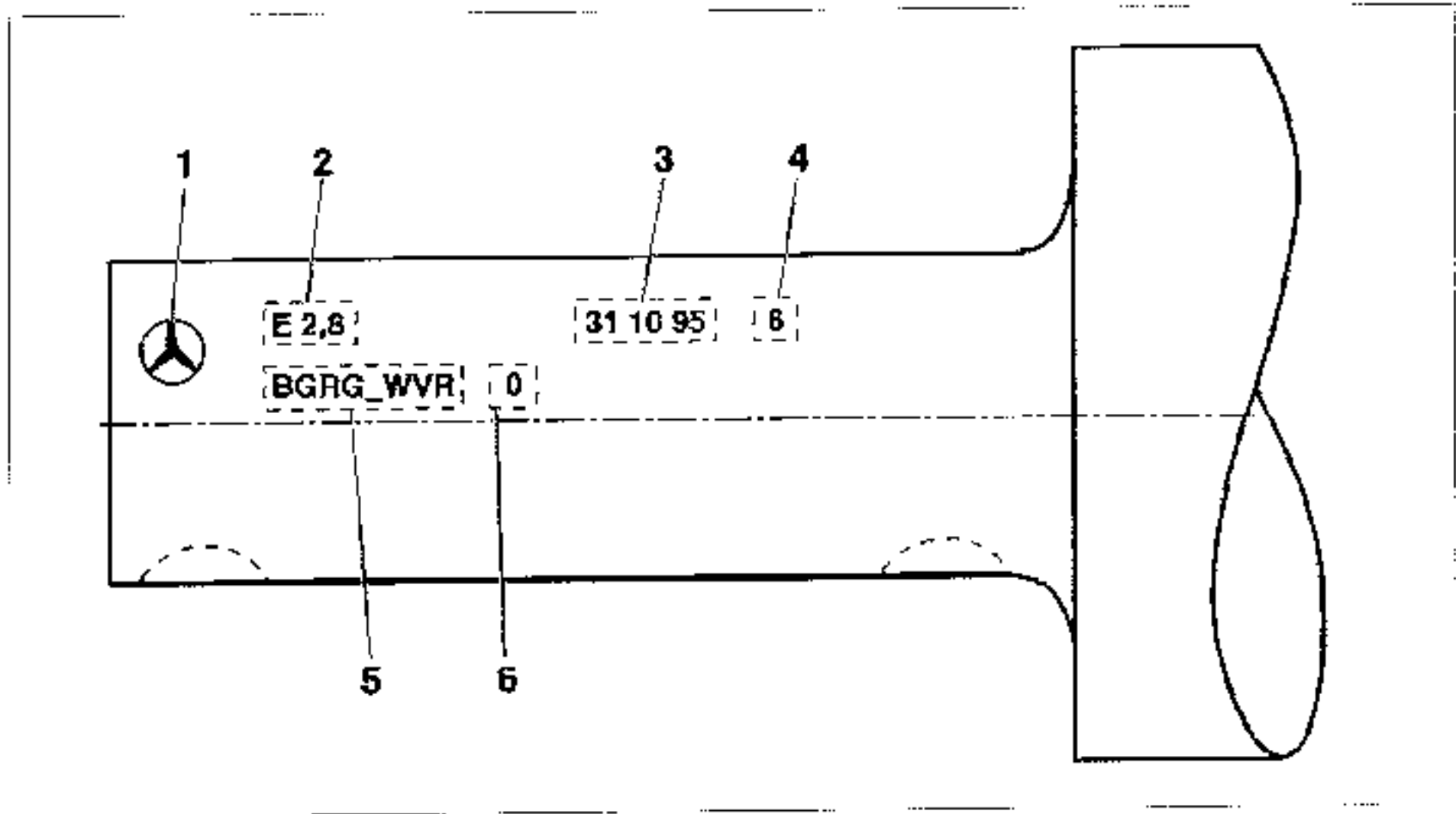

PC3.20 0245-55

Laser lettering on front of crankshaft:

- | | | | |
|---|------------------|---|--|
| 1 | Company emblem | 4 | Inspection digit of automatic measuring system |
| 2 | Mode designation | 5 | Crankshaft bearing journal \varnothing |
| 3 | Inspection date | 6 | Fit bearing width |

03-3165 Matching pistons and piston dimensions

When performing repairs, the pistons with the code letters stated below should be installed in the case of cylinder bores with "standard size".

Cylinder bore identification	Piston identification ¹⁾
A	A or X
X	X or A, B
B	B or X

1) If pistons with standard size are replaced when performing repairs because of a noise problem, match up the pistons properly in accordance with the cylinder bore identification.

Additional code when ordering pistons 52-A, 54=X, 56-B

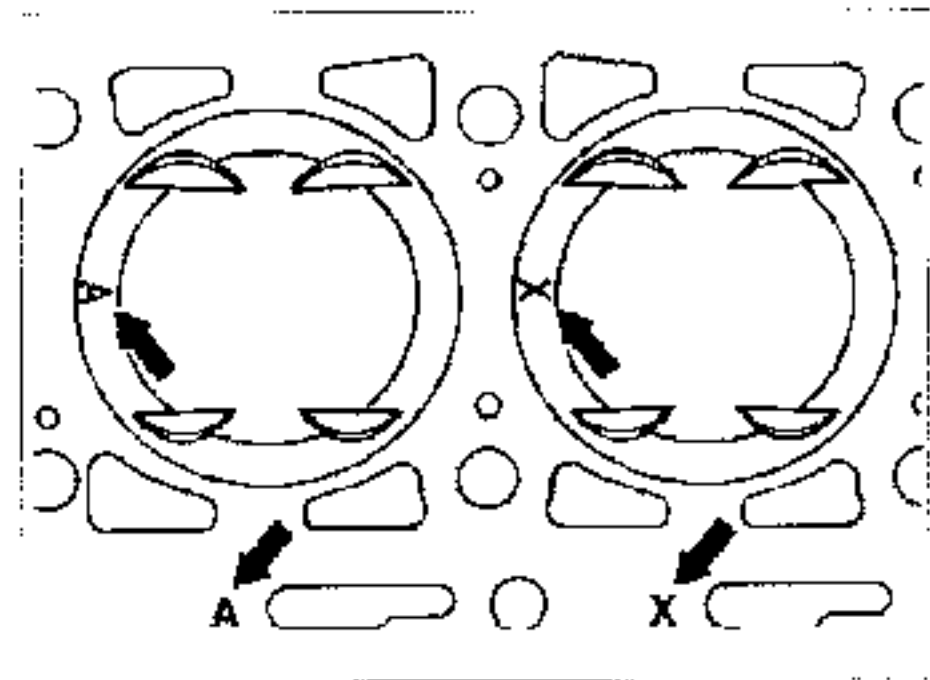

P03 5343-13

Note

When performing repairs, the cylinder bores should be finished to the dimensions of the existing pistons in accordance with the table for matching the pistons; see "Measuring, boring and honing cylinder bores" (01-1100).

Piston play when the pistons are new is 0.02 to 0.04 mm.

The measuring point is about 12 to 14 mm above the bottom edge of the piston at right angles to the piston pin. It is not possible to conduct an exact measurement of used pistons as the piston skirt has "sunk" at the measuring point provided.

01-1100 Measuring, boring and honing cylinder bores

Engines 104.98 ¹⁾

Allocation	Group No. ²⁾	Cylinder dia.	Piston dia
Standard \varnothing 88.5	A	88.500 - 88.506	88.473 - 88.479
	X	88.506 - 88.512	88.478 - 88.486
	B	88.512 - 88.518	88.485 - 88.491
1st repair size+0.5	A	89.000 - 89.006	88.973 - 88.979
	X	89.006 - 89.012	88.978 - 88.986
	B	89.012 - 89.018	88.985 - 88.991
2nd repair size+1.0	A	89.500 - 89.506	89.473 - 89.479
	X	89.506 - 89.512	89.478 - 89.486
	B	89.512 - 89.518	89.485 - 89.491

Engines 104.94/99 ¹⁾

Allocation	Group No. ²⁾	Cylinder dia.	Piston dia.
Standard \varnothing 89.9	A	89.900 - 89.906	89.873 - 89.879
	X	89.906 - 89.912	89.878 - 89.886
	B	89.912 - 89.918	89.885 - 89.891
1st repair size+0.25	A	90.150 - 90.156	90.123 - 90.129
	X	90.156 - 90.162	90.128 - 90.136
	B	90.162 - 90.168	90.135 - 90.141
2nd repair size+0.5	A	90.400 - 90.406	90.373 - 90.379
	X	90.406 - 90.412	90.378 - 90.386
	B	90.412 - 90.418	90.385 - 90.391

¹⁾ Except AMG engines

²⁾ The group code letters are located on the piston crown and are stamped in the contact surface of the crankcase.

Wear limit in direction of travel and in transverse direction		0.10
Permissible deviation of cylinder shape	when new	0.007
	wear limit	0.05
Permissible deviation of rectangularity related to cylinder height		0.05

Permissible waviness (Wt)	50 % of peak-to-valley height
Chamfering of cylinder bores	see note
Honing angle	50 10°

Commercially available tool

Quick callipers for internal measurements, dia. 80 - 100 mm

Note

When performing repairs, all the cylinder bores should be finished to the sizes of the existing pistons in accordance with the allocation table.

Measuring

Measure the cleared cylinder bores with an internal measuring instrument at the 3 measuring points (1, 2 and 3) in the longitudinal and transverse directions.

Measuring points 1 - 3

- A Longitudinal direction
- B Transverse direction
- a Upper reversal point of 1st piston ring
- b Bottom dead centre of piston
- c Lower reversal point of oil scraper ring

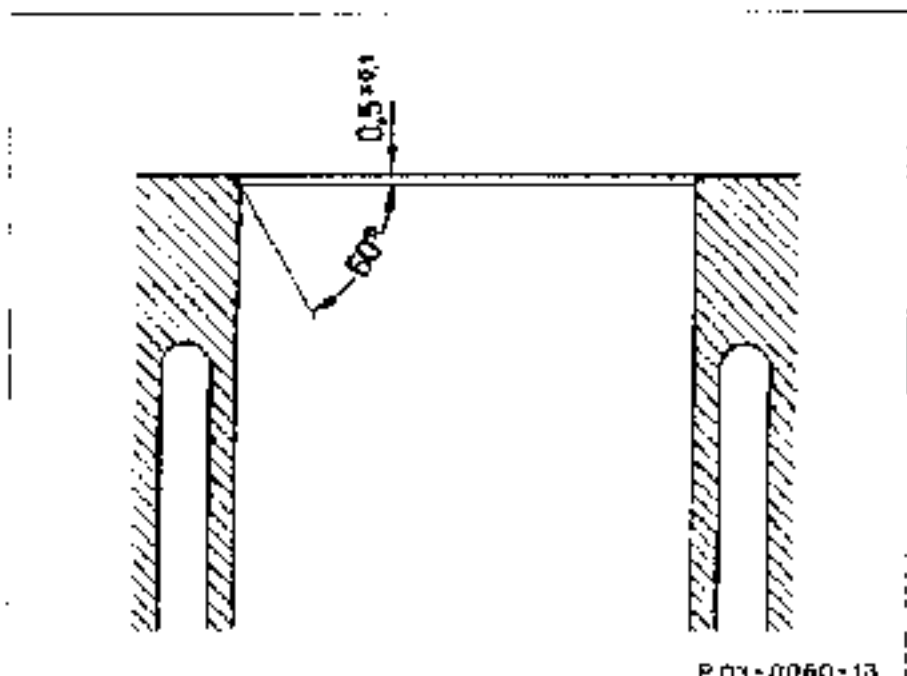
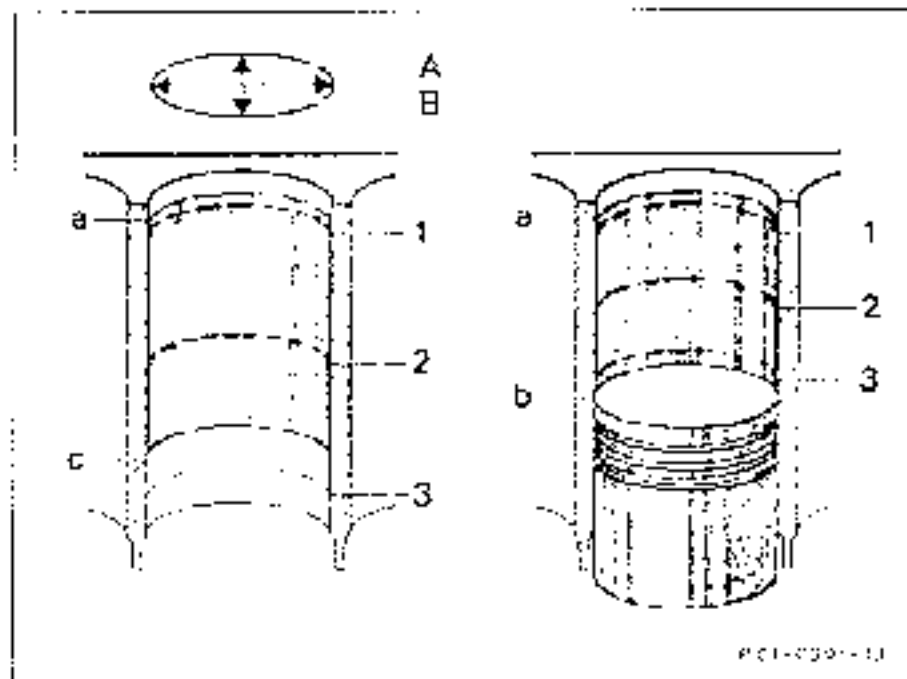

03-3130 Servicing, aligning and mounting conrod bearings

Preceding work:
Conrod removed

Operation no. of operation texts and work units or standard texts and flat rates:
03-6111 - 03 6401

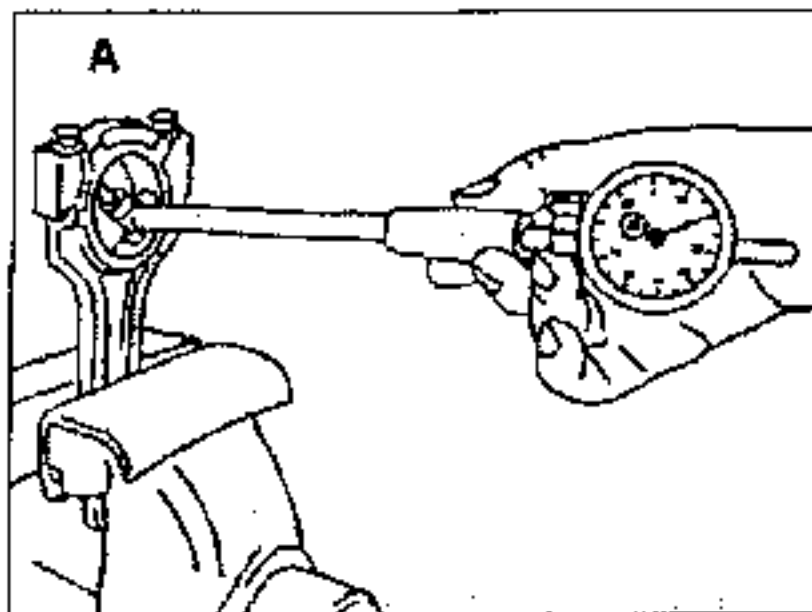

P03-5297-13

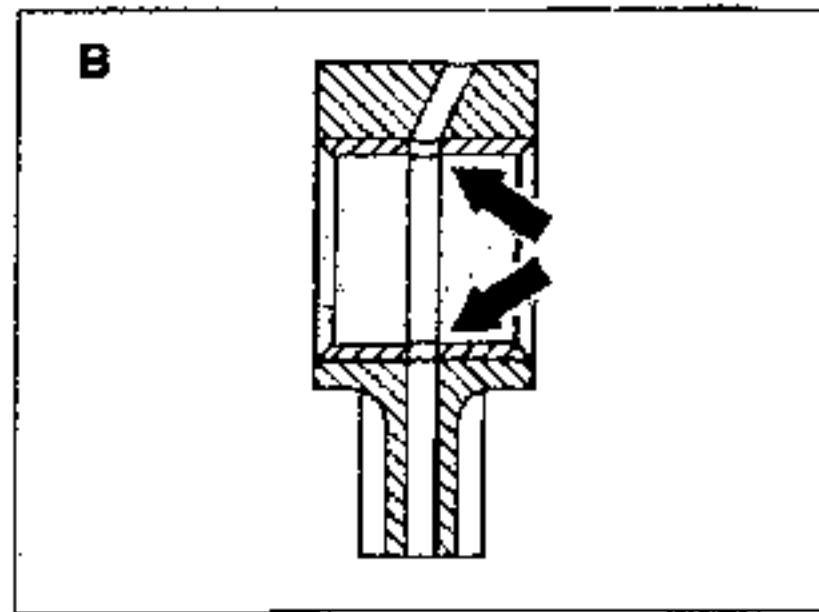

P03-5298-13

P03-5293-53

Repairing

Conrod bolts.....	check (03-3100)
Conrod bearing caps.....	install: oil thread and bolt head contact surface for this step and tighten to 40 Nm.
Conrod bearing basic bore.....	measure (Fig. A).

Note

If basic bore exceeds the value of 51.619 mm or is conical, dress contact surface of conrod bearing cap to max. 0.02 mm.

Machine conrod cap together with conrod.

New conrod bush.....	press in (Fig. B).
----------------------	--------------------

Note

Press in new conrod bush so that the oil drillings are aligned (arrows).

Insertion pressure 2450 N.

Conrod bush.....	turn or ream
Contact surfaces of conrod at side.....	dress on a dressing plate

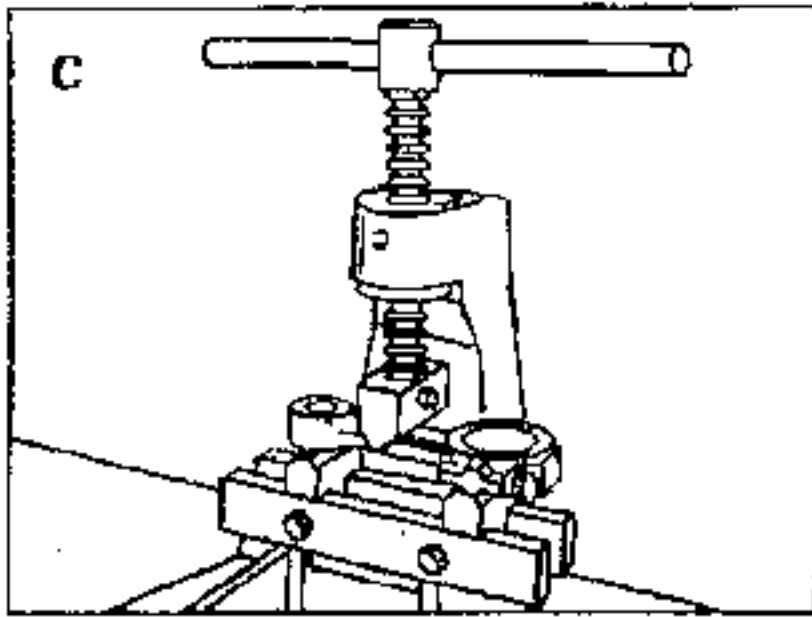

P03-5289-13

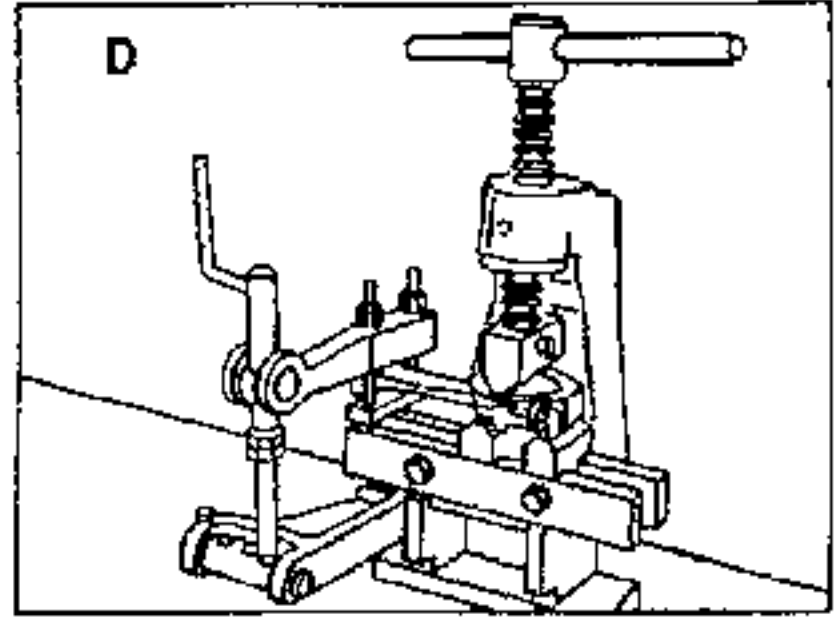

P03-5300-13

P03-5294-53

Aligning

- Conrod..... check with bearing shells and piston pins installed with conrod inspection equipment.
- Conrod..... align with conrod aligning equipment
- Parallelism of conrod bearing bore to conrod bush bore..... align (Fig. C).
- Twist of conrod bearing bore to conrod bush bore..... align (Fig. D).

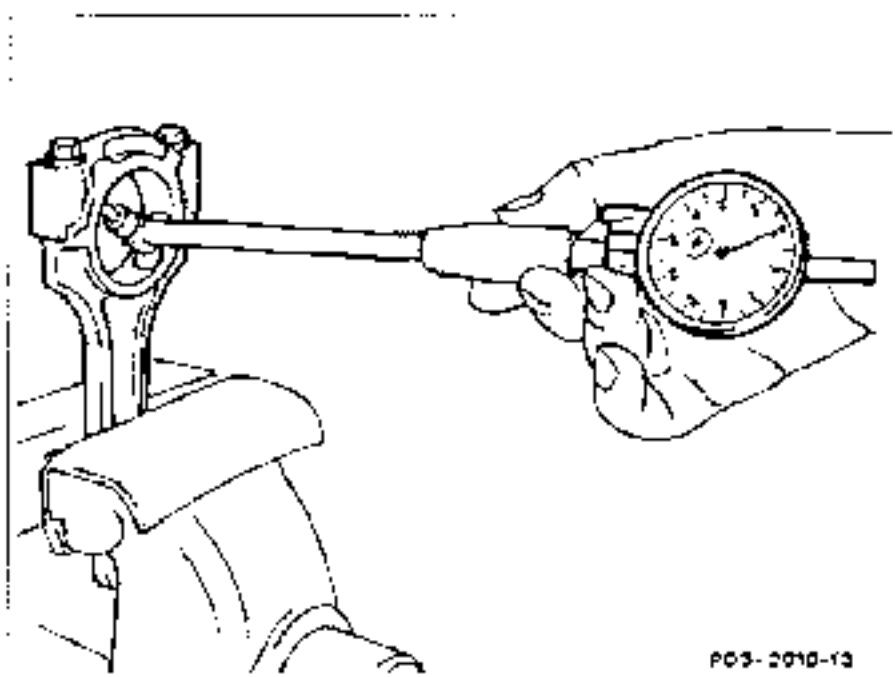

P03-2010-13

Fitting new bearings

- Conrod basic bore..... measure, note.
- Conrod bearing journal \varnothing measure, note.
- Conrod radial bearing play..... calculate.
- Conrod bearing shell..... match.

Conrod..... install on pistons (03-3160).

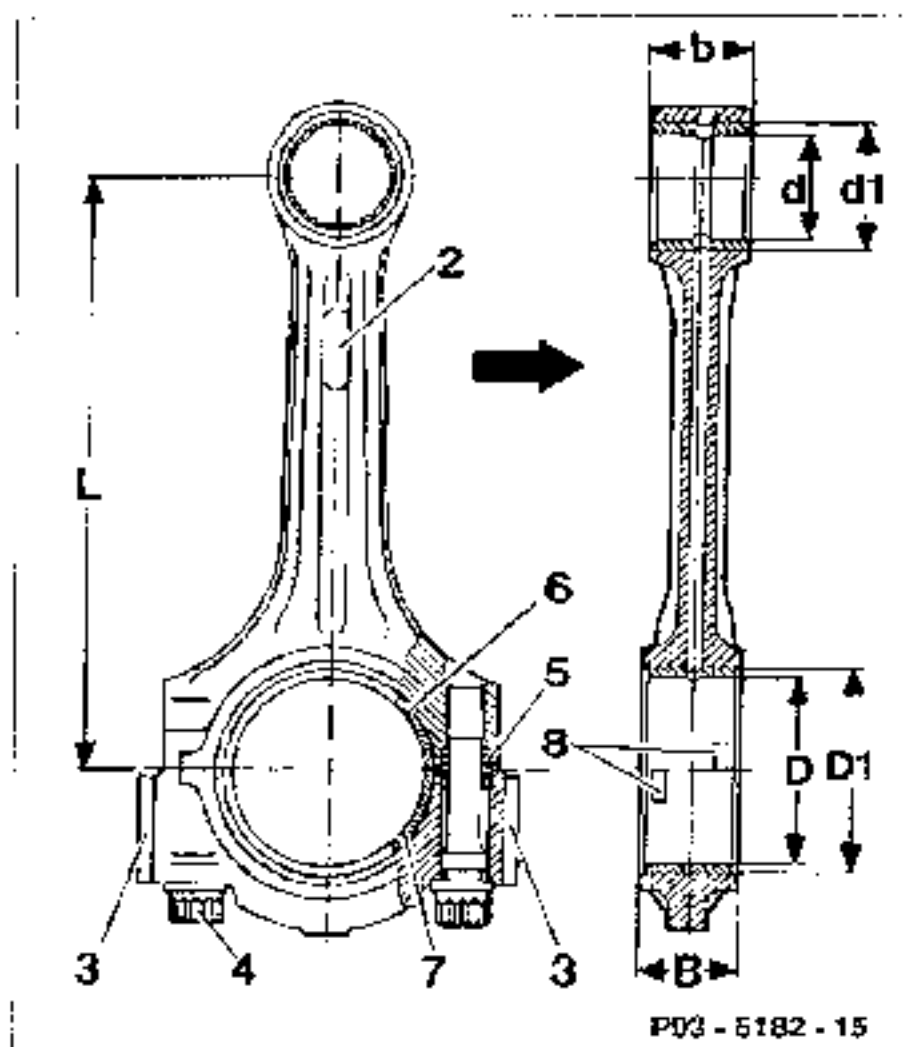

- | | | | |
|---|-------------------------|-------|-----------------------------|
| 2 | Identification | 6 | Top conrod bearing shell |
| 3 | Bottom balancing weight | 7 | Bottom conrod bearing shell |
| 4 | M9X1 conrod bolt | 8 | Bearing shell locating lugs |
| 5 | Dowel sleeve | Arrow | Direction of travel |

Data

Engine	104.94	104.98/99
Center of conrod bearing bore to center of conrod bush bore (L)	148.995 - 149.005	144.995 - 145.005
Width of conrod at conrod bearing bore (B)	21.948 - 22.000	
Width of conrod at conrod bush bore (b)	21.948 - 22.000	
Conrod bearing shell basic bore (D1)	51.500 - 51.519	
Conrod bush basic bore (d1)	24.500 - 24.571	

Data

Conrod bush inner \varnothing (d)	22.007 - 22.013
Piston pin play in conrod bush	0.013 - 0.018

Permissible twist of conrod bearing bore to conrod bush bore	0.15
Permissible difference in axial parallelism of conrod bearing bore to conrod bush bore	0.07
Permissible difference in concentricity of conrod bearing bore	0.01
Permissible difference in weight of complete conrod within an engine	4 g

Crankshaft identification and machining dimensions

Crankshaft	Size	Color coding on crankshaft web ²⁾	Machining dimensions ¹⁾
Conrod bearing journal \varnothing	Standard	none	47.955 - 47.965
	Standard 1 ²⁾	orange	47.945 - 47.955
	Standard 2 ²⁾	blue	47.935 - 47.945
	1st repair size	-	47.700 - 47.715
	2nd repair size	-	47.450 - 47.465
	3rd repair size	-	47.200 - 47.215
Conrod bearing journal width	4th repair size	-	46.950 - 46.965
	Standard		27.958 - 28.042
	Repair size up to		28.300

¹⁾ The crankshaft should be machined so as to maintain the specified bearing play with the existing bearing shells

²⁾ Up to 12/93

Test data

Conrod bearing play	radial	0.02 - 0.04
	axial	piston-guided

Conrod bearing shells

Color coding	red	yellow	blue
Wall thickness in mm			
Standard	1.806 - 1.810	1.810 - 1.814	1.814 - 1.818
Standard 1 ¹⁾	1.811 - 1.815	1.815 - 1.819	1.819 - 1.823
Standard 2 ²⁾	1.816 - 1.820	1.820 - 1.824	1.824 - 1.828
1st repair size	-	1.995 - 1.999	-
2nd repair size	-	2.060 - 2.064	-

Standard 1 and standard 2 wall thicknesses are not supplied as replacement parts.

Special tools

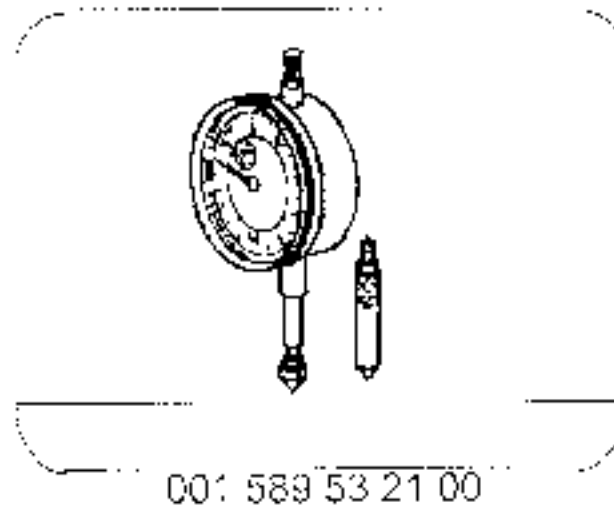
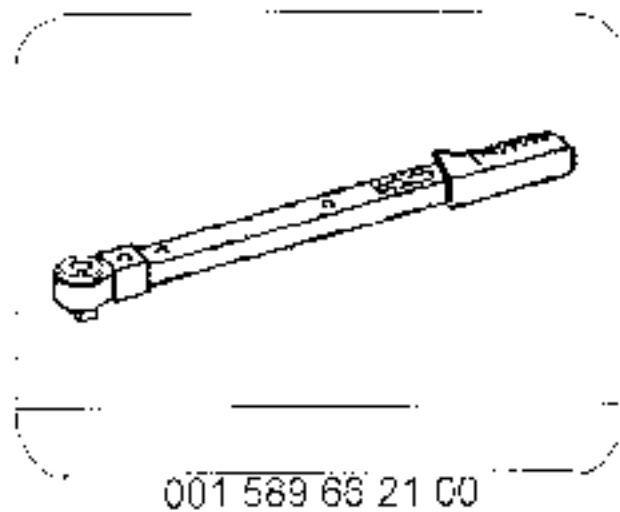

Commercially available tools

Conrod tester

e. g. Model BC 501
KWT
63128 Dietzenbach

Conrod aligning tool

e.g. Model BC 503
KWT
63128 Dietzenbach

Quick-caliper for internal measurements

Ø 20 - 40 mm

Ø 40 - 60 mm

Micrometer

0 - 25 mm

50 - 75 mm

Notes

Conrod and conrod caps are marked together (arrow).

Conrods which have been overheated because of bearing damage (blue discolouration) must not be re-used.

The conrod shaft must not have any cross scores and notches.

Conrods with machined conrod bush are supplied as a replacement part.

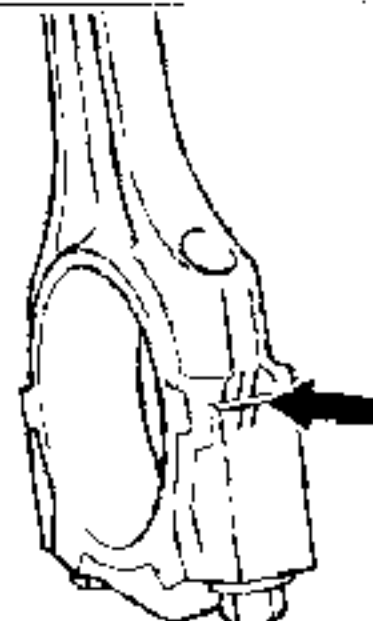

The conrod and the conrod cap are located relative to each other with fit sleeves.

Pay attention to difference in weight when replacing the conrod