

A compensating tank (1) in the trunk serves for venting the fuel tank (Fig. 47-2/1).

The compensating tank is connected to two lines (Fig. 47-2/2) entering the fuel filler connection and to one line extending into the outside air (Fig. 47-2/3).

If fuel is forced into the lines (2) with the fuel tank completely filled, the fuel can rise into the compensating tank. As soon as one of the two lines is free of fuel, the fuel flows back into the fuel tank, while the fuel vapors escape through the line (3) into the open air.

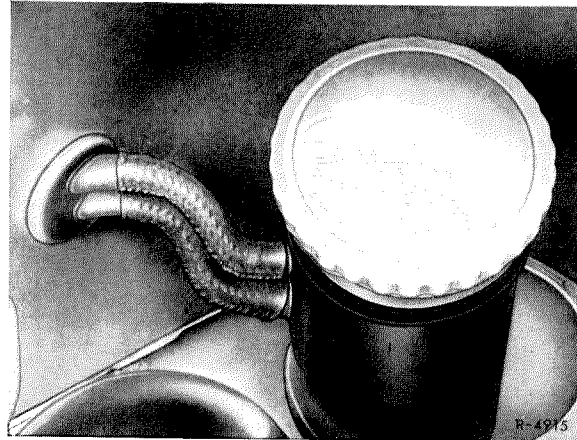

Fig. 47-2/2

Lines to fuel filler connection

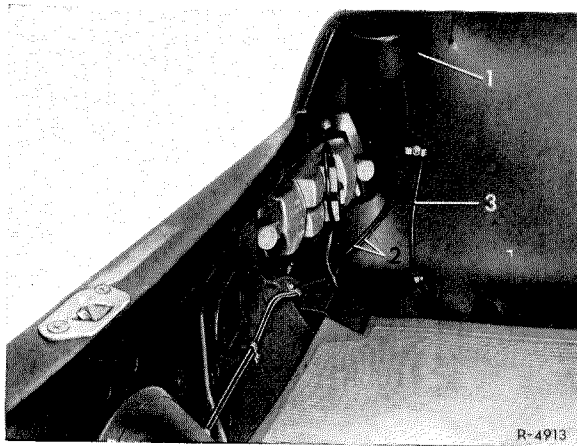

Fig. 47-2/1

1 Compensating tank                      3 Line to outside air  
2 Lines to fuel filler connection

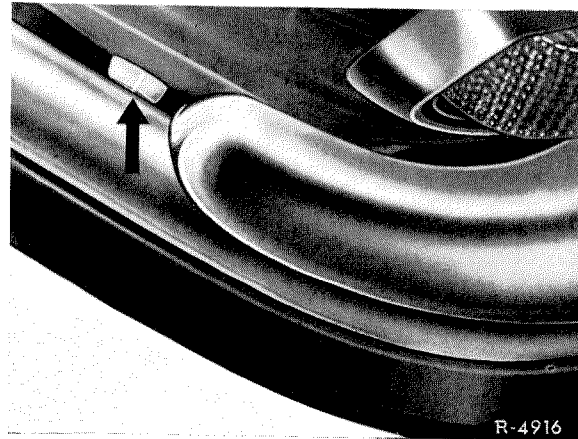

Fig. 47-2/3

Line to outside air

## Fuel Compensating Tank in USA Version Vehicles as from Model Year 1970

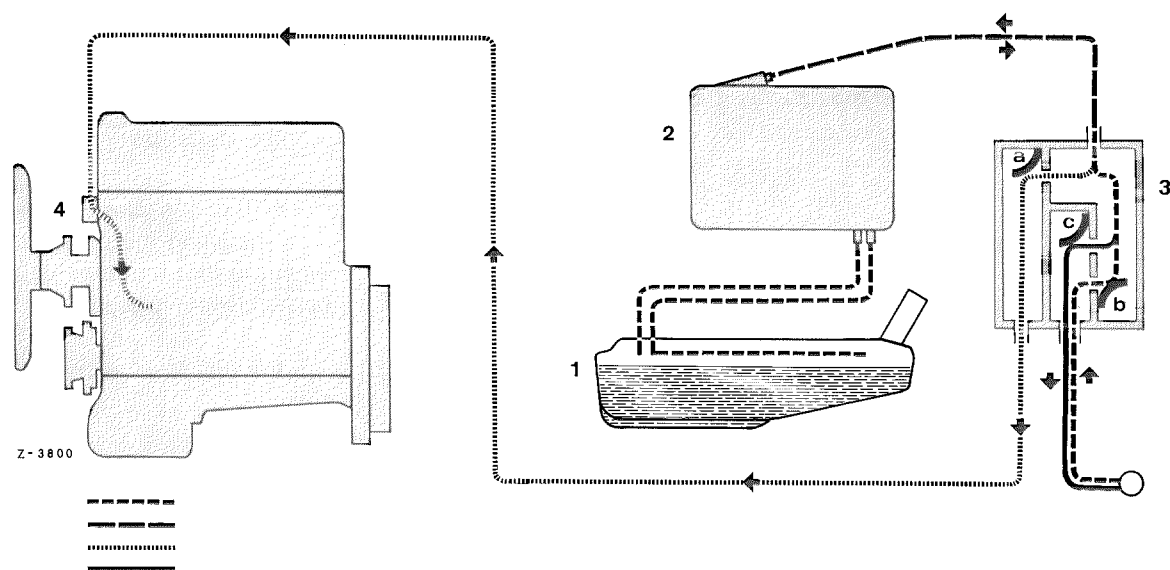

Fig. 47-2/4

- |                     |                           |                            |                         |
|---------------------|---------------------------|----------------------------|-------------------------|
| 1 Fuel tank         | 3 Valve system            | a Venting air inlet valve  | c Pressure relief valve |
| 2 Compensating tank | 4 Connection on crankcase | b Venting air outlet valve |                         |

As from Model Year 1970 fuel evaporative emissions are no longer permitted to escape into the ambient atmosphere. Consequently, these vehicles are provided with a larger (4.5 liter) compensating tank (2) and a combination valve system (3), which leads the evaporative emissions back to the engine via a line (8) (Fig. 47-2/4 and 47-2/5).

The venting line (6) leading to the valve system (3) is at the top of the compensating tank. The valve system is subdivided into the outlet air valve, the

inlet air valve and the pressure relief valve (a, b and c—refer to Fig. 47-2/4).

The outlet air valve (a) opens at a pressure of 0.012–0.018  $\text{kp/cm}^2$ , for Models 280 SE/9 3.5 and 300 SEL/9 3.5 at 0.025  $\text{kp/cm}^2$ . The evaporative emissions are flowing to the engine via the venting line (8), which runs in parallel to the fuel line (Fig. 47-2/5).

The venting line enters the chainbox (4) of the cylinder crankcase (Fig. 47-2/4) or on Models 280 SE/9 3.5, 300 SEL/9 3.5 and 300 SEL/8 6.3 into the oil pan.

The fuel evaporative emissions are sucked off via the crankcase venting system and will flow into the combustion chambers.

Prior to entering the crankcase or the oil pan a nozzle of 2 mm diameter in the pertinent connection meters the fuel evaporative emissions as follows:

If the pressure in the valve system (3) is 0.035 to 0.050  $\text{kp/cm}^2$ , or 0.055  $\text{kp/cm}^2$  in Models 280 SE/9 3.5 and 300 SEL/9 3.5, the pressure relief valve (c) will open and permit the fuel evaporations to flow into the ambient air via the venting line (7) (Fig. 47-2/5).

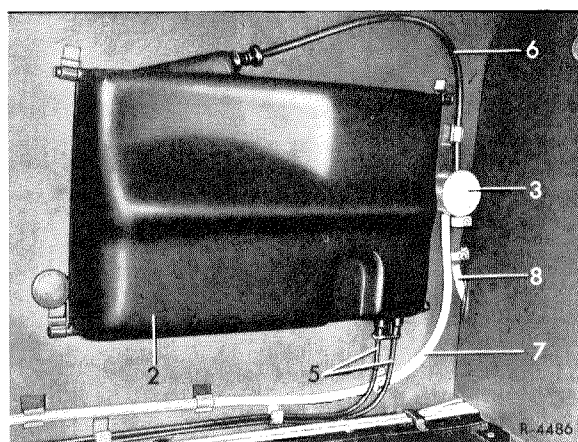

Fig. 47-2/5

- |                                     |                                |
|-------------------------------------|--------------------------------|
| 2 Compensating tank                 | 6 Venting line                 |
| 3 Valve system                      | 7 Venting line for ambient air |
| 5 Forward flow and return flow line | 8 Venting line to engine       |

Cooling down of the fuel tank (for example when parking the vehicle during the night) may result in a vacuum in the tank. To eliminate this vacuum, the tank is vented with fresh air via the venting valve (b) at an opening pressure of 0.012–0.018 kp/cm<sup>2</sup>, or of 0.0062 kp/cm<sup>2</sup> on Models 280 SE/9 3.5 and 300 SEL/9 3.5.

### **Removal and Installation of Compensating Tank**

---

The compensating tank must be completely removed together with the plastic lines or on USA version vehicles together with the valve system (3).

On Model 280 SL/8 the lines are in the rear center section. On this model, removal of the lines requires unscrewing a cover of the center section, as well as the cover on the fuel filler neck.

In addition, the foam piece above the plastic line in the rear center section must be removed.

During installation, be sure that the plastic lines are not bent sharply when installing the tank. Another important requirement is that the lines cannot chafe and that the perfect layout is assured.

The connecting hoses on the fuel filler neck must be installed with hose clips.