

Powered By **ALLDATA** Information

**ALLDATA** *diy.com* Leading Source of Online Diagnostic & Repair Information!

<a href="#">HELP</a>	<a href="#">VEHICLE</a>	<a href="#">ACCOUNT</a>	<a href="#">EXIT</a>
----------------------	-------------------------	-------------------------	----------------------

1987 Mercedes Benz 300D (124 Chassis) L6-2996cc 3.0L DSL SOHC Turbo 603

[Top - Vehicle](#)

↳ [Technical Service Bulletins](#)

↳ [Customer Interest](#)

↳ [A/T - Vacuum Modulator Adjustment](#)

[SEARCH](#)

or

[Contact ALLDATA](#)

[Notes](#)

### A/T - Vacuum Modulator Adjustment

REF. NO.

27/90

TO:

OUR MERCEDES-BENZ PASSENGER CAR DEALERS

DATE:

February 1993

SUBJECT:

ALL MODELS WITH AUTOMATIC TRANSMISSIONS 722.3 and 722.5 MODIFIED VACUUM MODULATOR

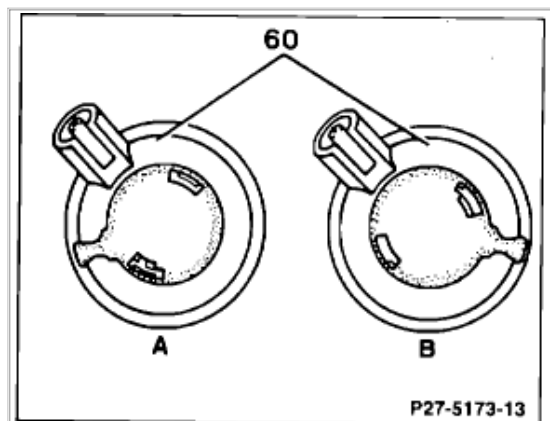

Figure 1

A Basic position

B Modulator pressure reduced by approx. 0.2 bar

[ZOOM](#)

[SIZED FOR PRINT](#)

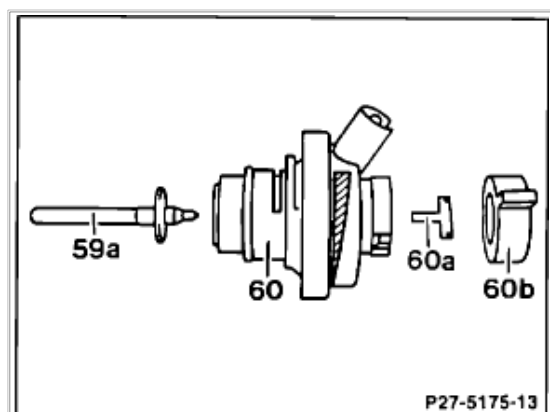

Figure 2

59a	Push rod
60	Vacuum modulator
60a	Adjustment key
60b	Sealing cap

ZOOM

SIZED FOR PRINT

As of August 1992, a modified vacuum modulator (60, Figures 1 and 2) is installed on automatic transmissions 722.3 and 722.5.

The sealing cap (60b, Figure 2) for the adjusting screw of this vacuum modulator is made of plastic (previous version was rubber). With this cap, modulator pressure can be reduced by approx. 0.2 bar.

Once the modulator is set to the specified modulator pressure, the cap is installed in the basic position (A, Figure 1). By turning the cap (60b, Figure 2) counterclockwise from position A to position B (Figure 1) it is possible to reduce the modulator pressure by approx. 0.2 bar, if a customer complains of harsh upshifts. This correction is achieved by turning the cap all the way to the end stop. With this cap, it is no longer necessary to check the modulator pressure with a pressure gauge.

With the installation of the new vacuum modulator (60, Figure 2), the push rod (59a) is also modified.

Important note:

If further correction of the modulator pressure is needed, it can be adjusted as previously by removal of the cap (60b, Figure 2).

The cap is destroyed when removed and must be replaced after completion of the work. The new cap must be pressed on in the basic position after modulator pressure is adjusted to specifications.

Parts Information

See latest Parts Microfiche.

Copyright © 2008 ALLDATA LLC

[Terms of Use](#)