

03-324 Replacement of front radial seal on crankshaft

Tightening torques	Nm	(kpm)
Bolt M 18 x 1.5 x 45 to crankshaft	270-330	(27-33)
Bolts M 8 x 20	35	(3.5)

Special tools

Torque wrench, 3/4" drive,
150-500 Nm (15-50 kpm)

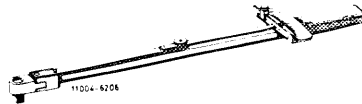

001 589 31 21 00

Puller for balance plate

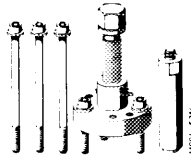

116 589 10 33 00

Supporting lock

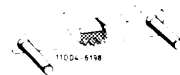

110 589 00 40 00

Socket 27 mm



001 589 65 09 00

Puller for spacing ring



616 589 00 33 00

Installer for radial seal

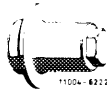

130 589 00 61 00

Commercially available tool

Adapter, 3/4" female to
1/2" male drive

e. g. Hazet, 5630 Remscheid,
order No. 1058 R-1

Note:

These engines feature oil pans with and without machined faces around the radial seal mounting hole (arrow).

Oil pans with plain faces always require radial seals with half shoulders, whereas oil pans with machined faces accept both half and full shoulders.

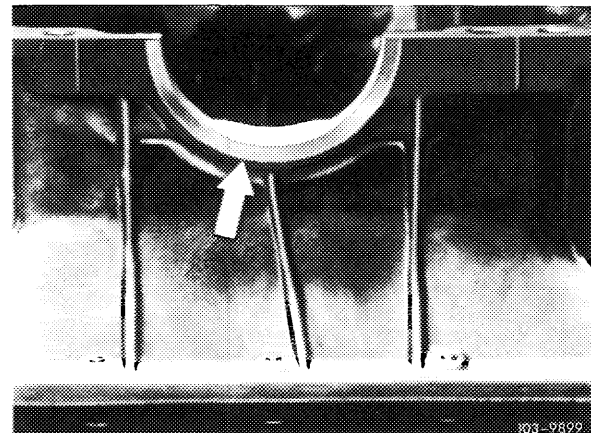

Oil pan with machined face

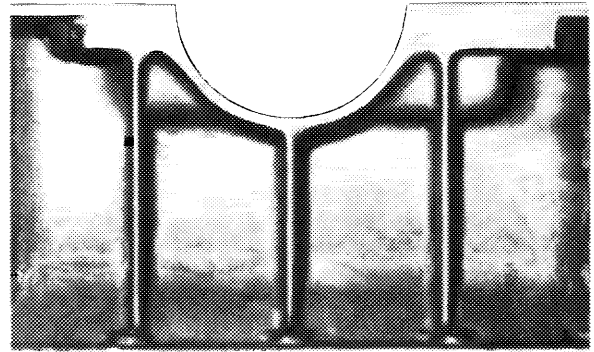

Oil pan with plain face

103-10294

Combined radial seals are available for repair purposes.

They consist of two different materials and have a sectional outer ring.

Inside: Silicone (white)
 Outside: Polyacrylic (black)

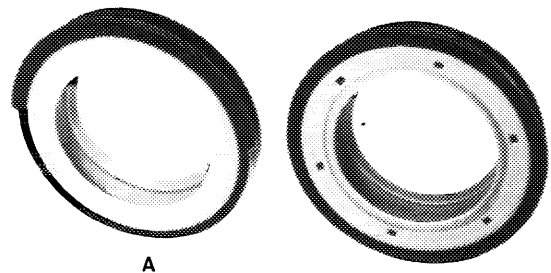

A Radial seal with half shoulder
 B Radial seal with full shoulder

103-9897

These combined radial seals (black outside, white inside) must only be used in conjunction with hard chromeplated placing rings (26), part No. 615 031 01 51.

In contrast, the combined radial seals which are black outside and green inside may also be used with spacing rings not having chrome-plating.

Materials:

Inside: Viton (green)
 Outside: Acrylic (black)

Removal

- 1 Remove radiator and fan.
- 2 Remove pulley (19a), vibration damper (20) and balance plate (24) (03-340).

Engines 615, 616

- | | |
|-------------------------|------------------------|
| 15 Bolt M 18 x 1.5 x 45 | 24 Balance plate |
| 16 Disk springs | 25 Radial seal |
| 17 Bolts M 8 x 20 | 26 Spacing ring |
| 18 Washer | 27 Woodruff key |
| 18a Thrust washer | 28 Crankshaft sprocket |
| 19a Pulley | 30 Crankshaft |
| 23 Dowel pins 8 x 8 | |

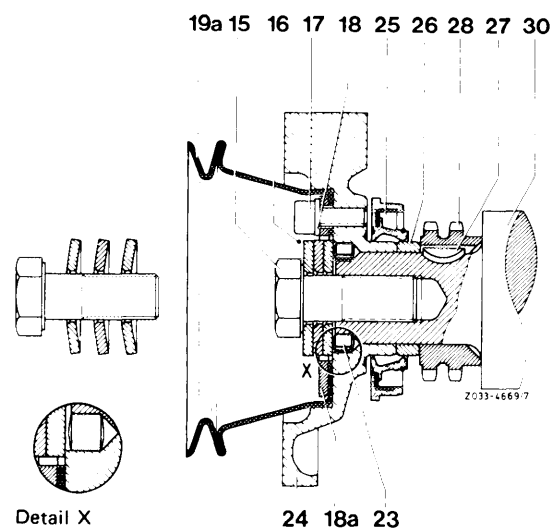

3 Prise out radial seal, using screwdriver. Be sure not to damage crankshaft journal or mounting hole.

15 16 19a 20 23 24 25 26 28 27 30

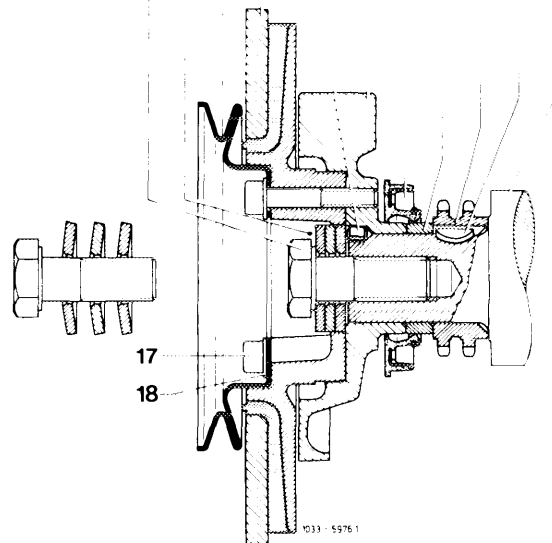

Engine 617

- | | |
|-------------------------|------------------------|
| 15 Bolt M 18 x 1.5 x 45 | 23 Dowel pin 8 x 8 |
| 16 Disk spring | 24 Balance plate |
| 17 Bolt M 8 x 45 | 25 Radial seal |
| 18 Washer | 26 Spacing ring |
| 19a Pulley | 27 Woodruff key |
| 20 Vibration damper | 28 Crankshaft sprocket |
| | 30 Crankshaft |

4 If spacing ring feels worn, remove with aid of puller.

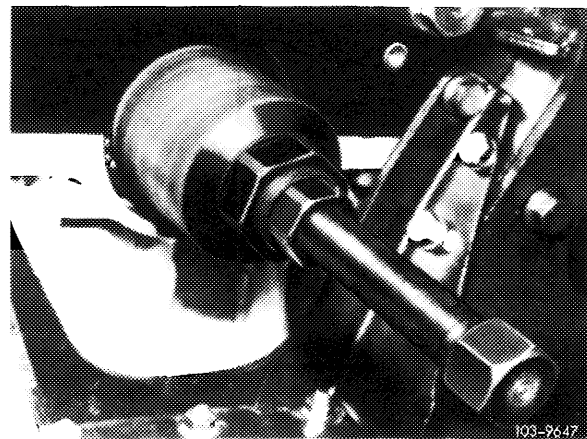

Installation

5 Deburr and clean radial seal mounting hole.

Note: If removed radial seal showed signs of leakage at outer shoulder, coat new radial seal with sealant, part No. 001 989 29 20 or part No. 001 989 46 20, prior to insertion; apply sealant to outer shoulder in region of joints.

6 Install new spacing ring (26).

7 Moisten sealing lip of new radial seal with oil and fit using installer.

Caution:

Radial seal must be exactly at right-angles to crankshaft journal because it may otherwise leak.

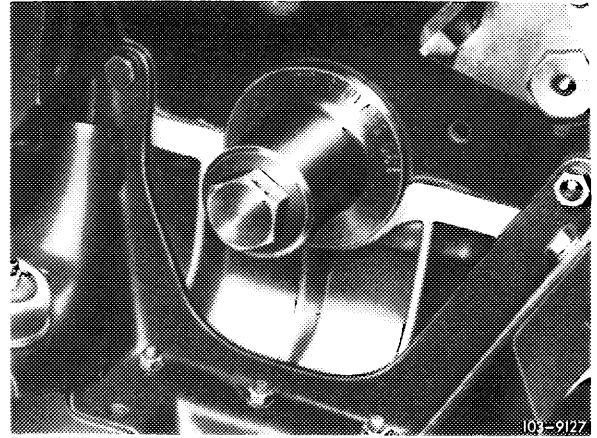

8 Install balance plate, vibration damper and pulley (03-340).

9 Install fan and radiator.