

33-300 Adjustment of wheel bearing end play

Data

Wheel bearing end play	0,01-0,02
------------------------	-----------

Lubricants

Quantity	In wheel cap: Grease quantity approx. 15 g (approx. up to edge of bead)
Series grade: up to October 1982	Anti-friction bearing grease (refer to Specifications for service products sheet 265)
Series grade: starting November 1982 and repair grade ²⁾	High-temperature anti-friction bearing grease (refer to Specifications for service products sheet 265.1) ¹⁾

¹⁾ Available in screw cans of 150 g, part no. 000 989 49 51.

²⁾ The high-temperature anti-friction bearing grease has already been used on vehicles with floating caliper brake (model 126.043/126.044) from start of series September 1981

Tightening torque	Nm
Hex. socket screw of clamping nut	14

Special tools

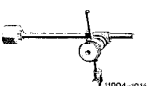
Pulling and mounting tool for wheel cap		116 589 22 33 00
Holder for dial gauge for adjusting wheel bearing end play		363 589 02 21 00

Conventional tool

Dial gauge A DIN 878	e. g. made by Mahr, D-7300 Esslingen order no. 810
----------------------	---

Note

To prevent mix-ups, fill front wheel hubs during repairs suitably with high-temperature anti-friction bearing grease only. When subsequently using high-temperature anti-friction bearing grease in front wheel hubs which were previously filled with anti-friction bearing grease or multi-purpose grease, renew complete grease charge throughout. Avoid mixing high-temperature anti-friction bearing grease with anti-friction bearing grease or multi-purpose grease.

33-300 Adjustment of wheel bearing end play

1 Jack-up vehicle, remove front wheel.

2 Pull-off wheel cap with fixture (023).

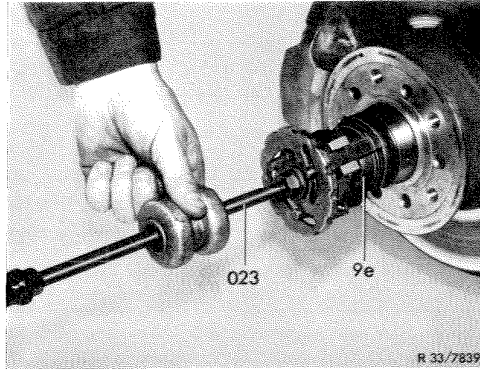

3 Remove contact spring for radio suppression.

4 Push brake pads away from brake disc (42-160).

Note: On vehicles with fixed caliper brake, make sure that the brake pads are not resting against brake disc, swivel cylinder housing of floating caliper away, if required (42-160).

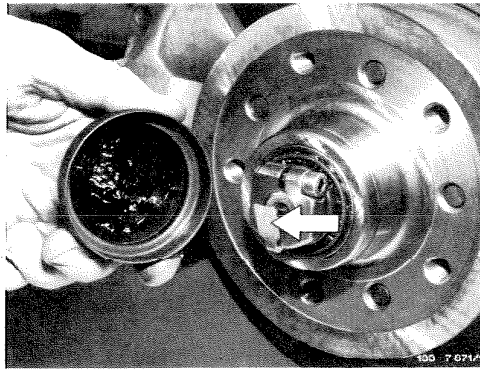

5 Loosen hex. socket screw of clamping nut (0d), tighten clamping nut well while simultaneously rotating hub (9) to the extent that hub will be hard to turn. Then slacken clamping nut again for approx. 1/3 turn and release tension by means of a blow against wheel spindle (5a) with a plastic hammer.

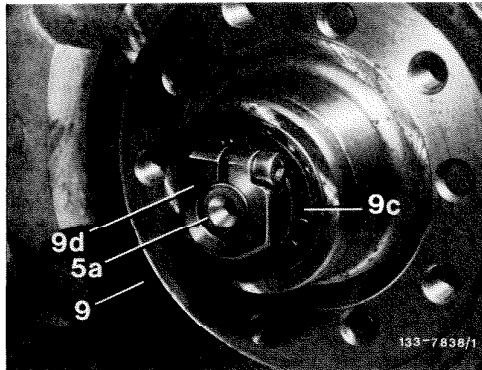

6 Place tester (015) on front wheel hub and set dial gauge (022) to approx. 2 mm preload.

Note: For measuring wheel bearing play, the tester (015), part no. 116 589 12 21 00, valid up to now, may also be used.

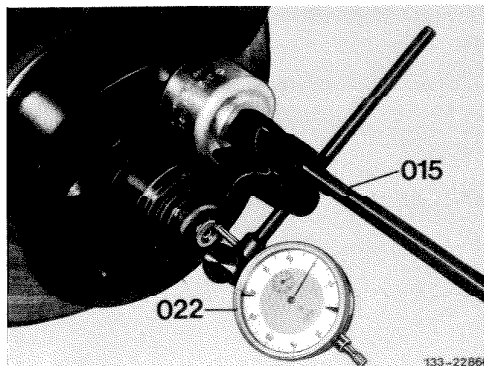

33-300 Adjustment of wheel bearing end play

7 Check end play of wheel hub by energetic pulling and pushing at flange.

Rotate wheel hub several times each time prior to measuring.

Attention!

Wheel hub should not rotate while measuring. Each rotating motion of wheel hub is indicated on dial gauge, so that accurate reading of the actual end play is not possible.

Front wheel hub without ABS

- 5 Steering knuckle
- 7 Supporting joint
- 9 Front wheel hub
- 9a Radial sealing ring
- 9b Tapered roller bearing inside
- 9c Tapered roller bearing outside
- 9d Clamping nut
- 9e Wheel cap
- 9f Contact spring
- 34 Brake disc
- 35 Covering plate

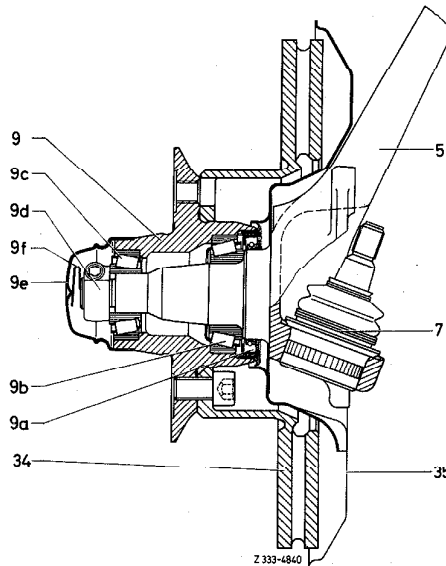

Front wheel hub with ABS

- 5 Steering knuckle
- 9 Front wheel hub
- 9a Radial sealing ring
- 9b Tapered roller bearing inside
- 9c Tapered roller bearing outside
- 9d Clamping nut
- 9e Wheel cap
- 9f Contact spring
- 34 Brake disc
- 42 Rpm sensor
- 42a Hex. socket screw

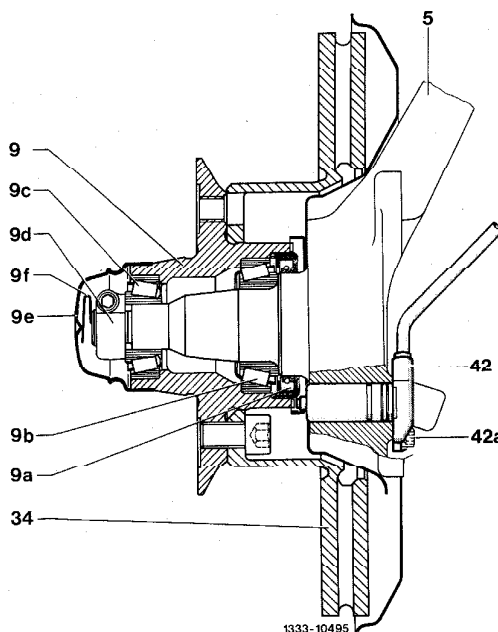

33-300 Adjustment of wheel bearing end play

8 Tighten hex. socket screw of clamping nut and check end play once again.

9 Insert contact spring for radio suppression.

10 Fill hub cap with specified grease approx. up to edge of bead.

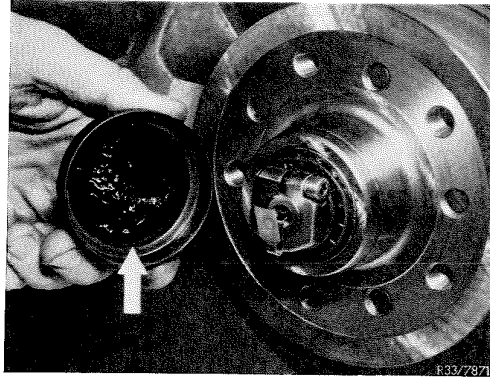

11 Press-on wheel cap by means of device (023).

12 Mount front wheel, lower vehicle.

