

P41-0006-33

- | | |
|---|--|
| Drive shaft | remove and install (41-050). |
| Front and rear drive shaft (1,2) | separate, plug together (step 2). |
| Rubber sleeve (4) | pull on and off (step 3). |
| Rubber mount (7) with grooved ball bearing (8) and protective cap (6) | pull off, press on, remove locking ring (5) on vehicles up to 07/82.
Two-legged puller 000 589 88 33 00 with pulling legs 116 589 03 33 00, pressing-on sleeve 126 589 03 15 00 (steps 4 to 7). |
| Rear protective cap (6a) | remove, plug on (step 8). |

41-100 R and R center bearing

Grooved ball bearing (8)	press out of and in rubber mount (7), check and replace if required. Pressing-out, pressing-in tool 116 589 09 43 00 (steps 9 to 11).
Spline shaft profile (28)	grease with specified grease (refer to Specifications for Service Products page 266.2).

Special tools

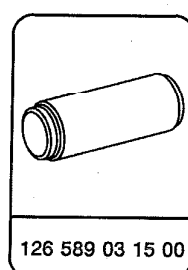
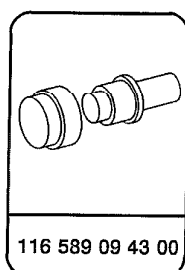
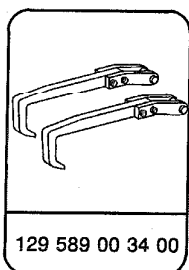
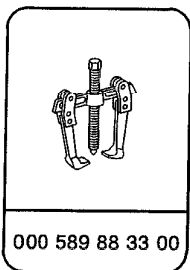

- 1 Remove drive shaft (41-050).
- 2 Separate front and rear drive shaft at clamp connection.

Note

On vehicles starting 08/82 the front and rear drive shaft are shown in relation to each other (arrows).

The drive shaft components are individually pre-balanced at the factory. To eliminate any residual unbalance which might still be present, the complete drive shaft including the flexible couplings, is rebalanced. For this reason, when disassembling the complete drive shaft (e.g. when changing the drive shaft intermediate bearing) the individual parts must be marked in relation to each other (if no markings are in place) for correct reassembly.

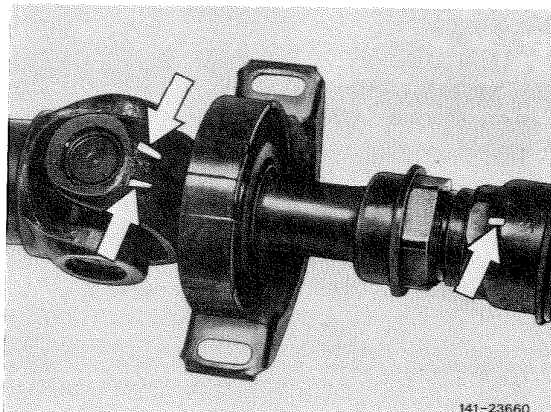

141-23660
141-23660

On vehicles up to 07/82, mark the individual drive shaft parts in relation to each other (arrows).

Installation note

Grease spline shaft profile with specified grease (refer to factory approved service products list).

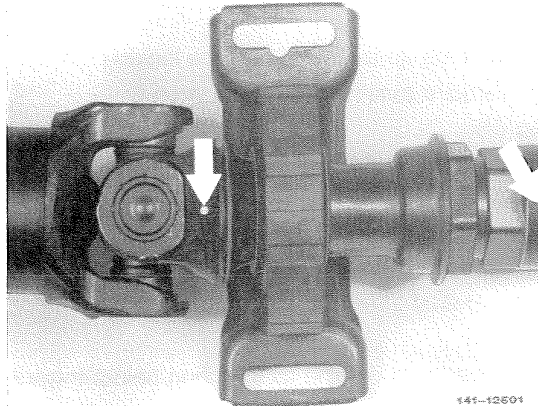

141-12591

141-12591

3 Pull off rubber sleeve (3) via serrations.

Installation note

Pay attention to correct seat of rubber sleeve on small diameter.

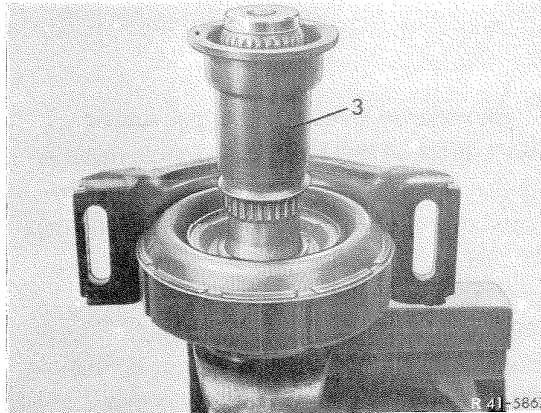

R 41-5867

R41-5867

4 On vehicles up to 07/82, pull rubber mount and grooved ball bearing together with two-legged puller 000 589 88 33 00 from fork-type joint.

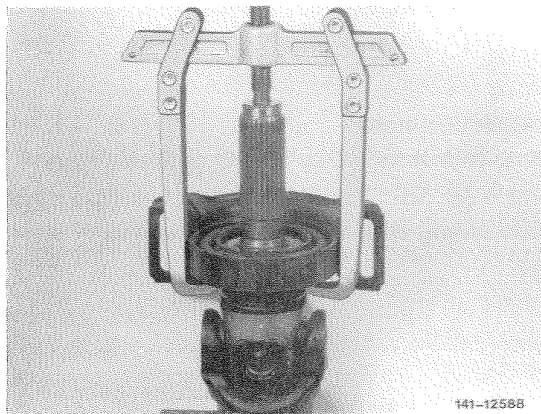

141-12588

141-12588