

### Electrical Test Program – Component Locations

**Model 202**  
**(Wagen shown)**  
 (not USA)

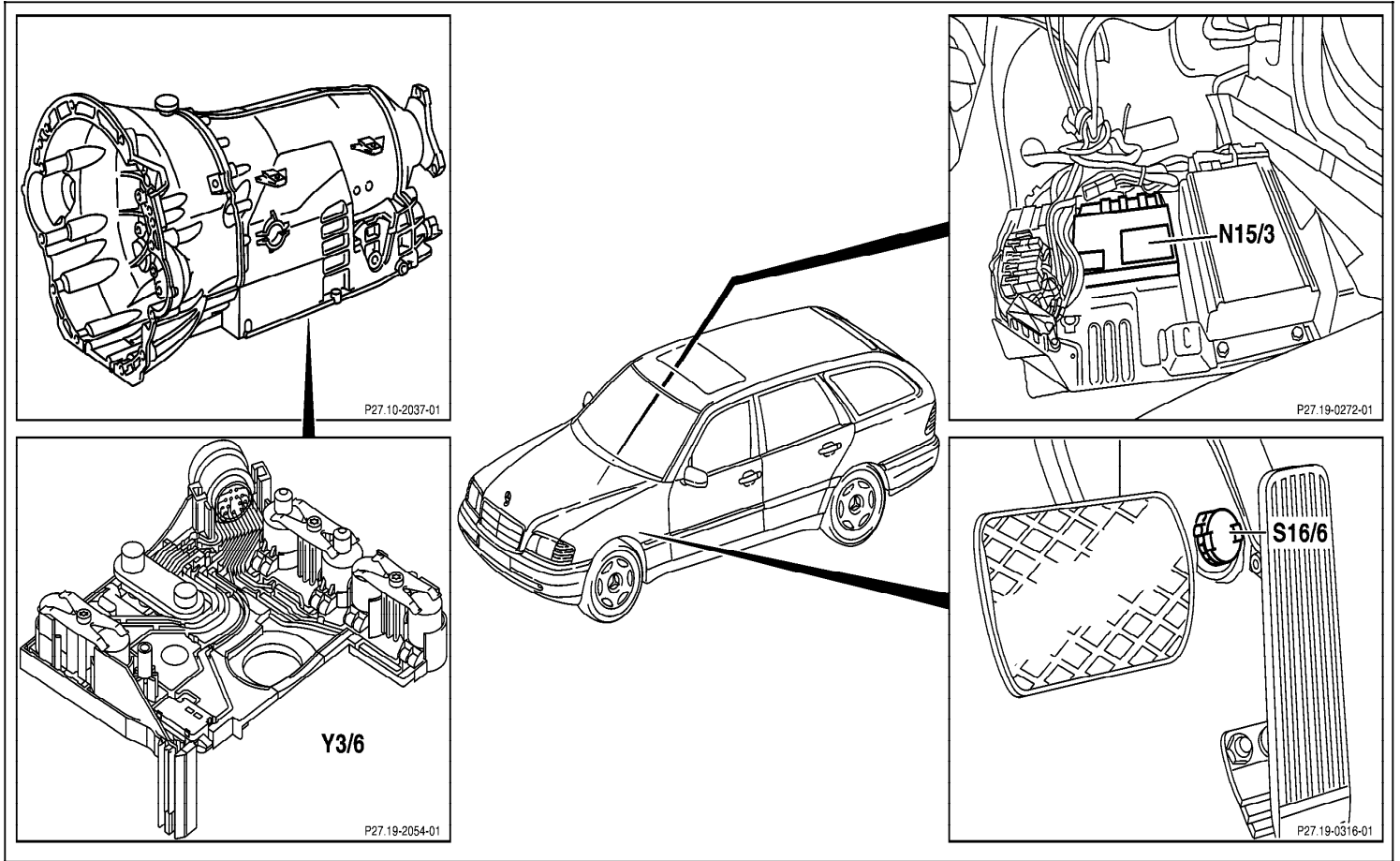

N15/3 ETC control module  
 S16/6 Kick-down switch  
 Y3/6 Valve unit (ETC)

P27.19-2058-09

### Electrical Test Program – Component Locations

Model 208

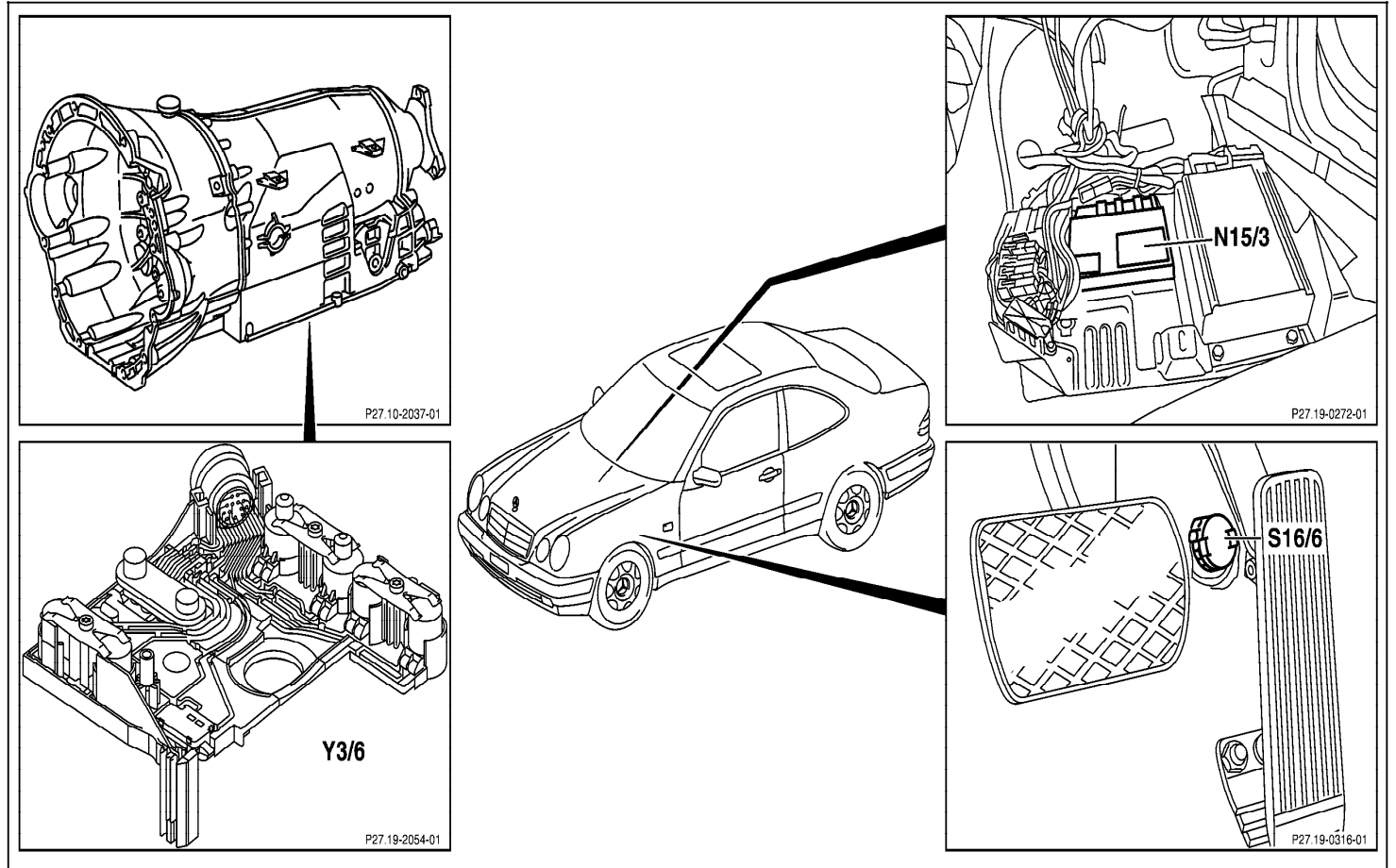

N15/3 ETC control module  
 S16/6 Kick-down switch  
 Y3/6 Valve unit (ETC)

P27.19-2059-09

### Electrical Test Program – Component Locations

#### Model 210

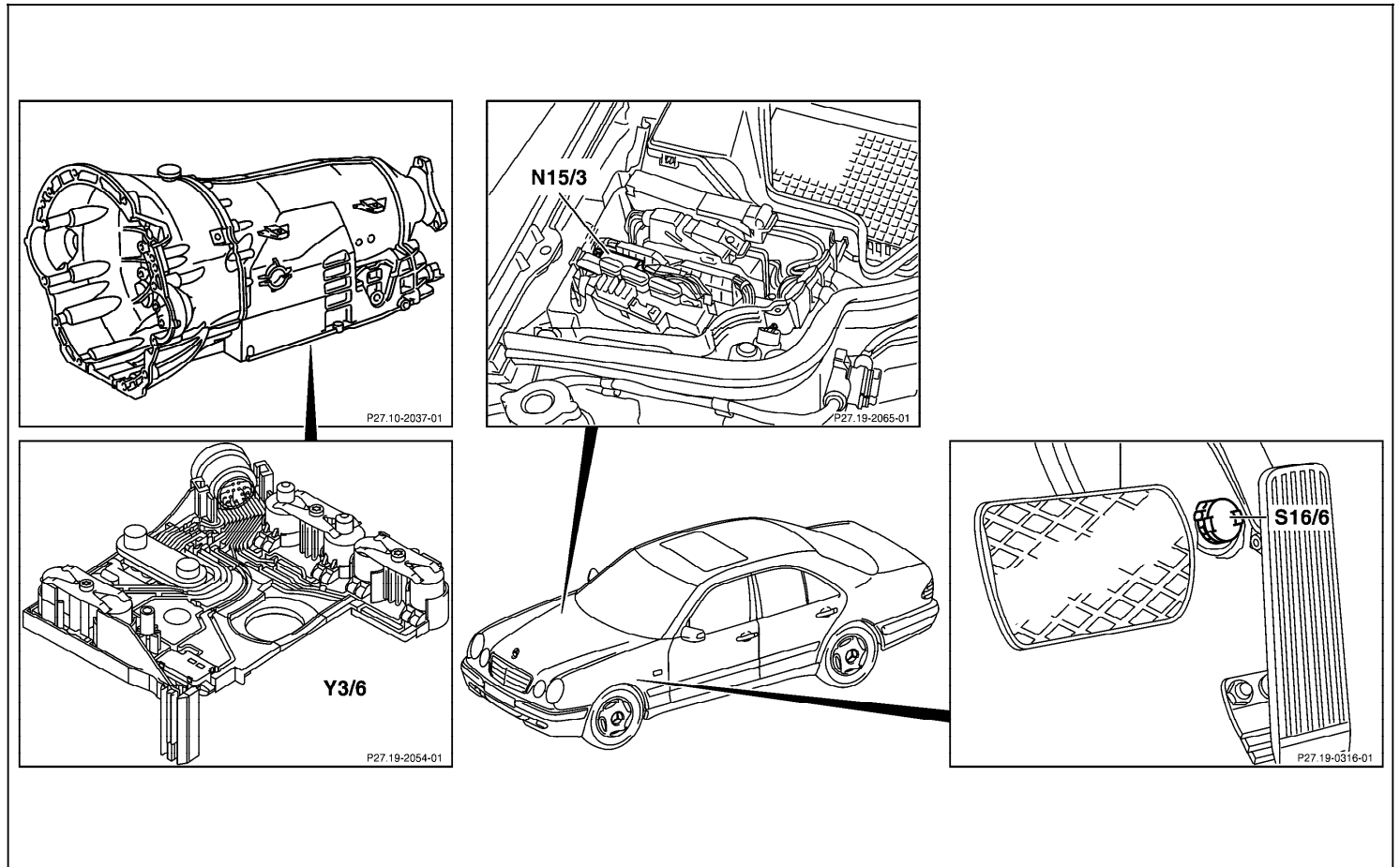

- N15/3 ETC control module
- S16/6 Kick-down switch
- Y3/6 Valve unit (ETC)

P27.19-2060-09

Electrical Test Program – Component Locations

Components of the Center Console Shift Gate

Models 129, 140, 170, 202, 208, 210 without "Touch Shift" shown

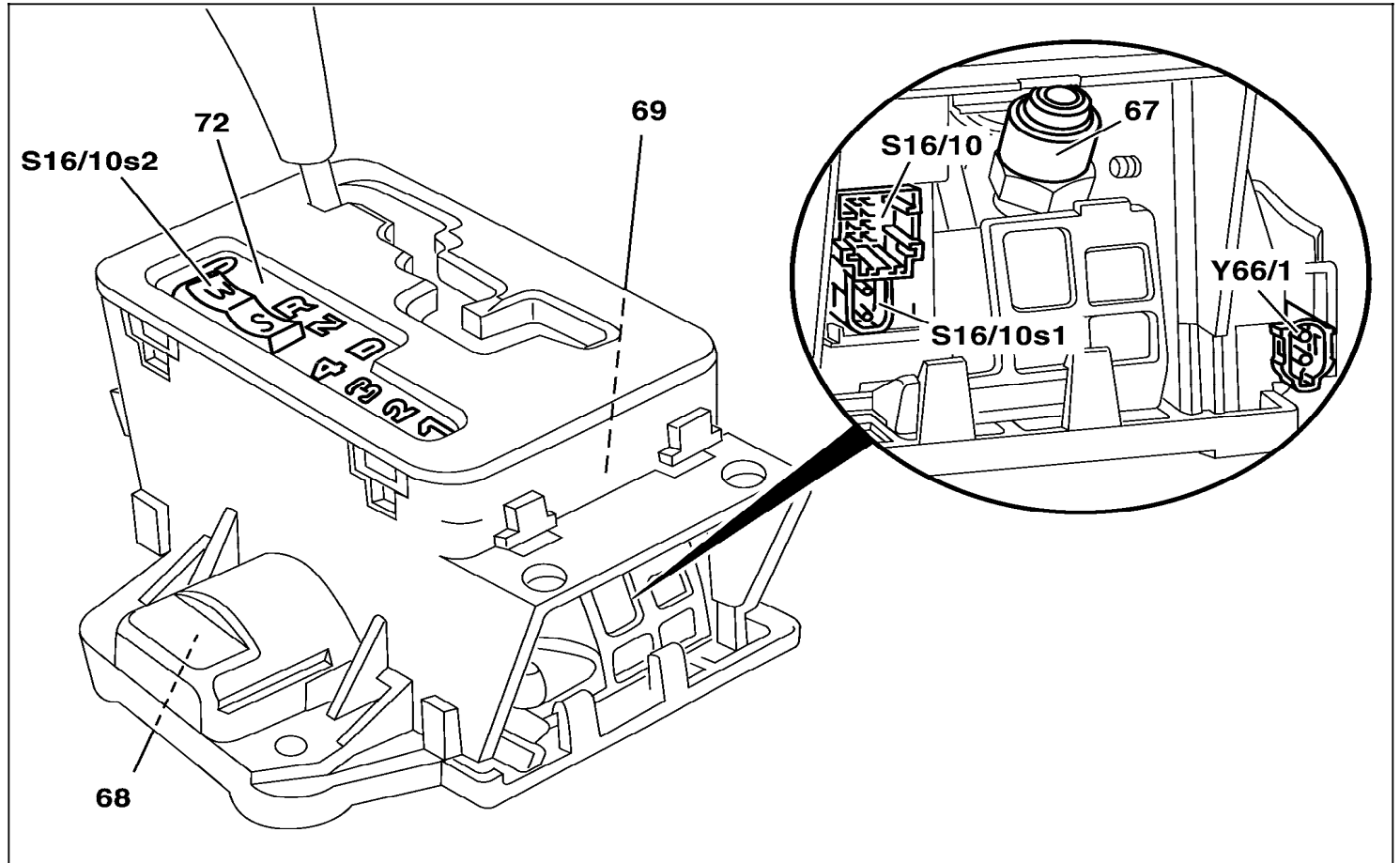

- 67 Shift stop
- 68 De-coupler
- 69 R/P lock
- 72 Position indicator
- S16/10 Transmission range recognition switch
- S16/10s1 Backup lamp switch
- S16/10s2 W/S program switch
- Y66/1 R/P lock valve

P27.60-2074-06

Electrical Test Program – Component Locations

Components of the  
Center Console Shift  
Gate  
Model 163 without  
"Touch Shift" shown

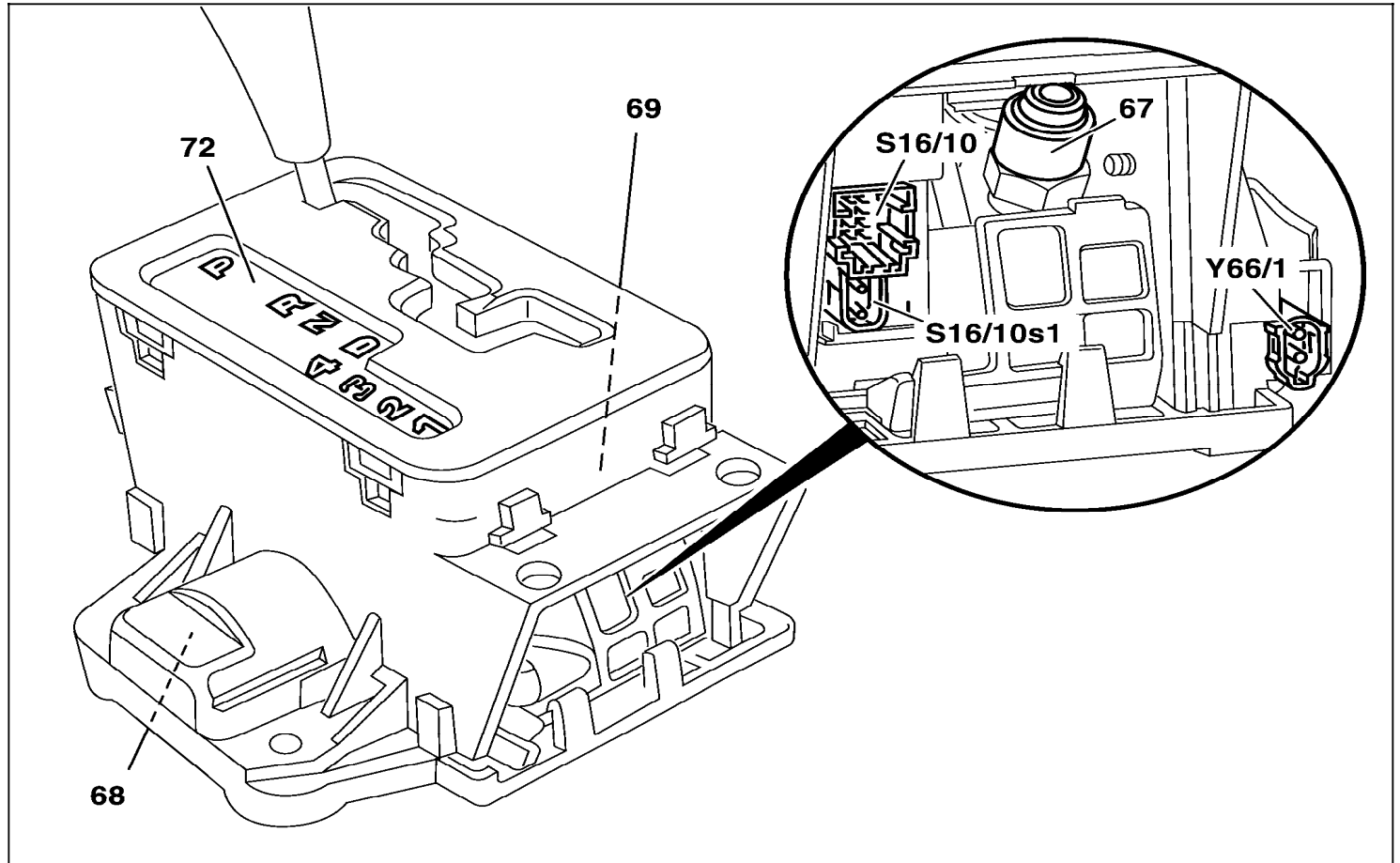

- 67 Shift stop
- 68 De-coupler
- 69 R/P lock
- 72 Position indicator
- S16/10 Transmission range recognition switch
- S16/10s1 Backup lamp switch
- Y66/1 R/P lock valve

P27.60-2076-06

Electrical Test Program – Component Locations

Electrical/Electronic components shown

- 2a Electrical conductor plate
- 11 Harness connector
- Y3/6 Valve unit (ETC)
- Y3/6y1 Modulating pressure regulating solenoid valve
- Y3/6y2 Shift pressure regulating solenoid valve
- Y3/6y3 1-2/4-5 shift solenoid valve
- Y3/6y4 3-4 shift solenoid valve
- Y3/6y5 2-3 shift solenoid valve
- Y3/6y6 PWM solenoid valve (torque convertor lock-up)
- Y3/6n2 RPM sensor 2
- Y3/6n3 RPM sensor 3
- Y3/6s1 Starter lock-out contact
- Y3/6b1 Transmission oil temperature sensor

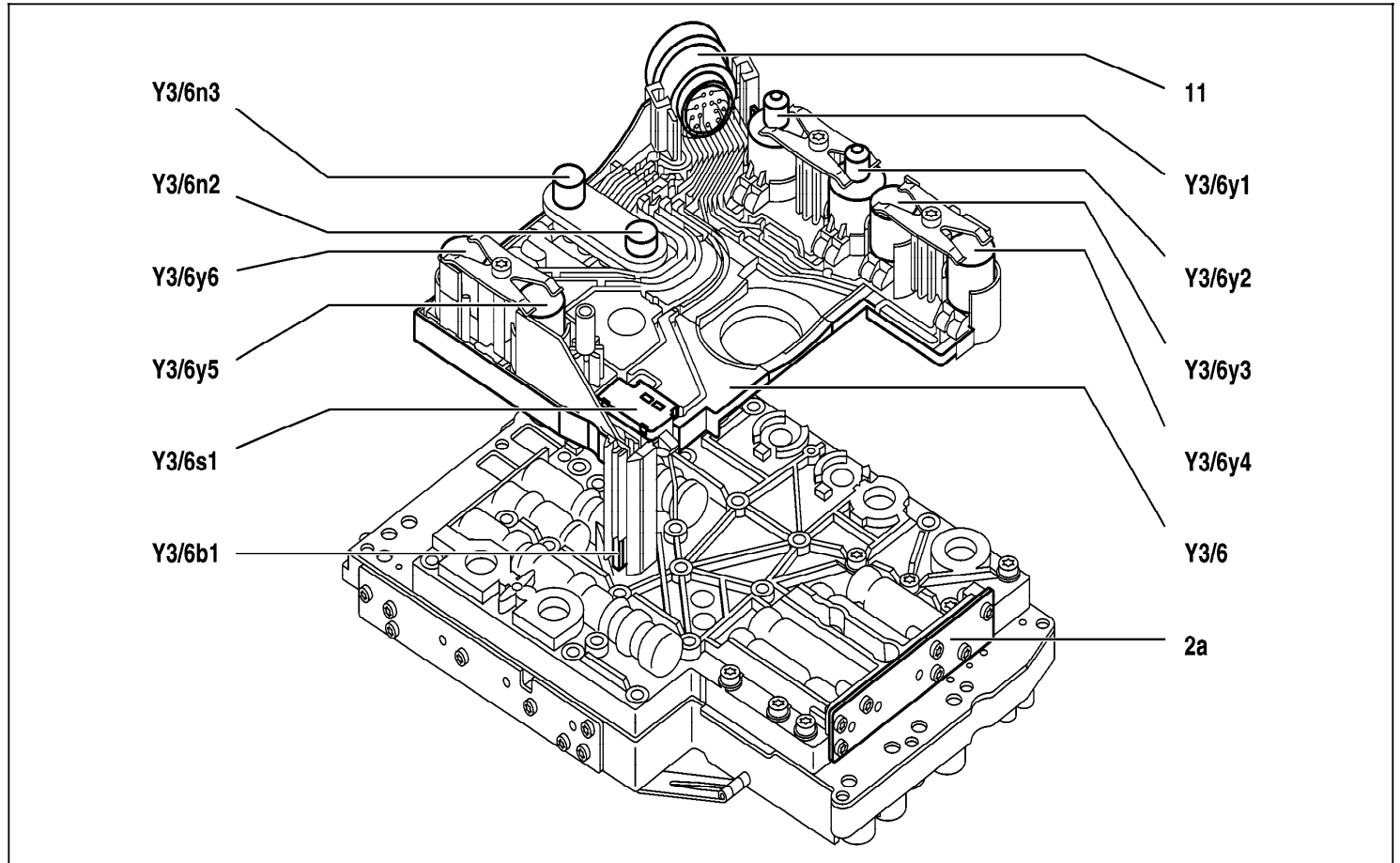

P27.10-0340-79

**Electrical Test Program – Preparation for Test**

1. Review sections: 11, 12, 21, 22 entirely,
1. Ignition: **OFF**,
2. Remove ETC control module (N15/3),
3. Connect socket box and test cable according to connection diagram on following pages: 22/2 through 22/7,
4. Review 21 entirely before performing the electrical testing in 23

Electrical wiring diagrams, location of grounds and connectors:

**Wiring Diagrams:**

Group 27 of respective Electrical Troubleshooting Manual (ETM)

**Special Tools**

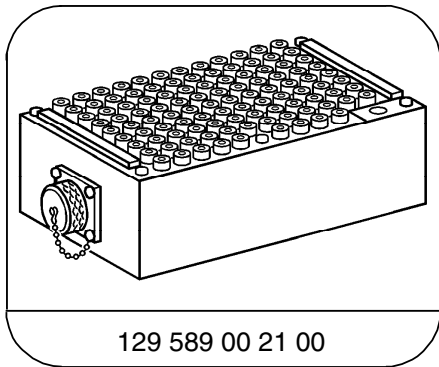

129 589 00 21 00

126-pin socket box

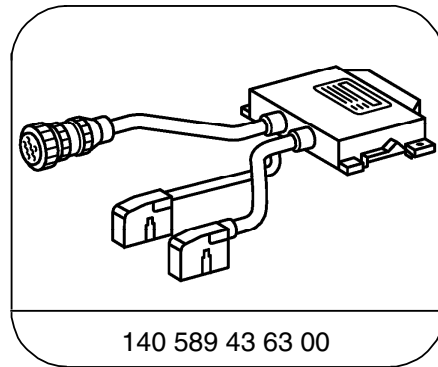

140 589 43 63 00

Test cable, 30-pin

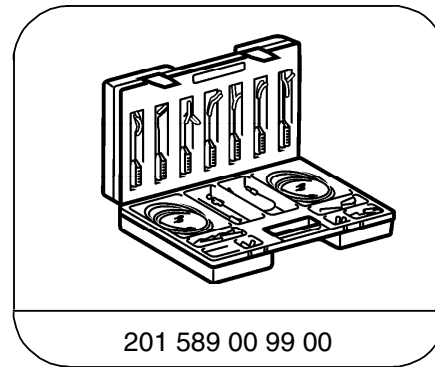

201 589 00 99 00

Electrical connecting set

**Test equipment; See MBUSA Standard Service Equipment Program**

Description	Brand, model, etc.
Digital multimeter	Fluke models 23, 77 III, 83, 85, 87

### Electrical Test Program – Preparation for Test

#### Connection Diagram – Socket Box Model 129

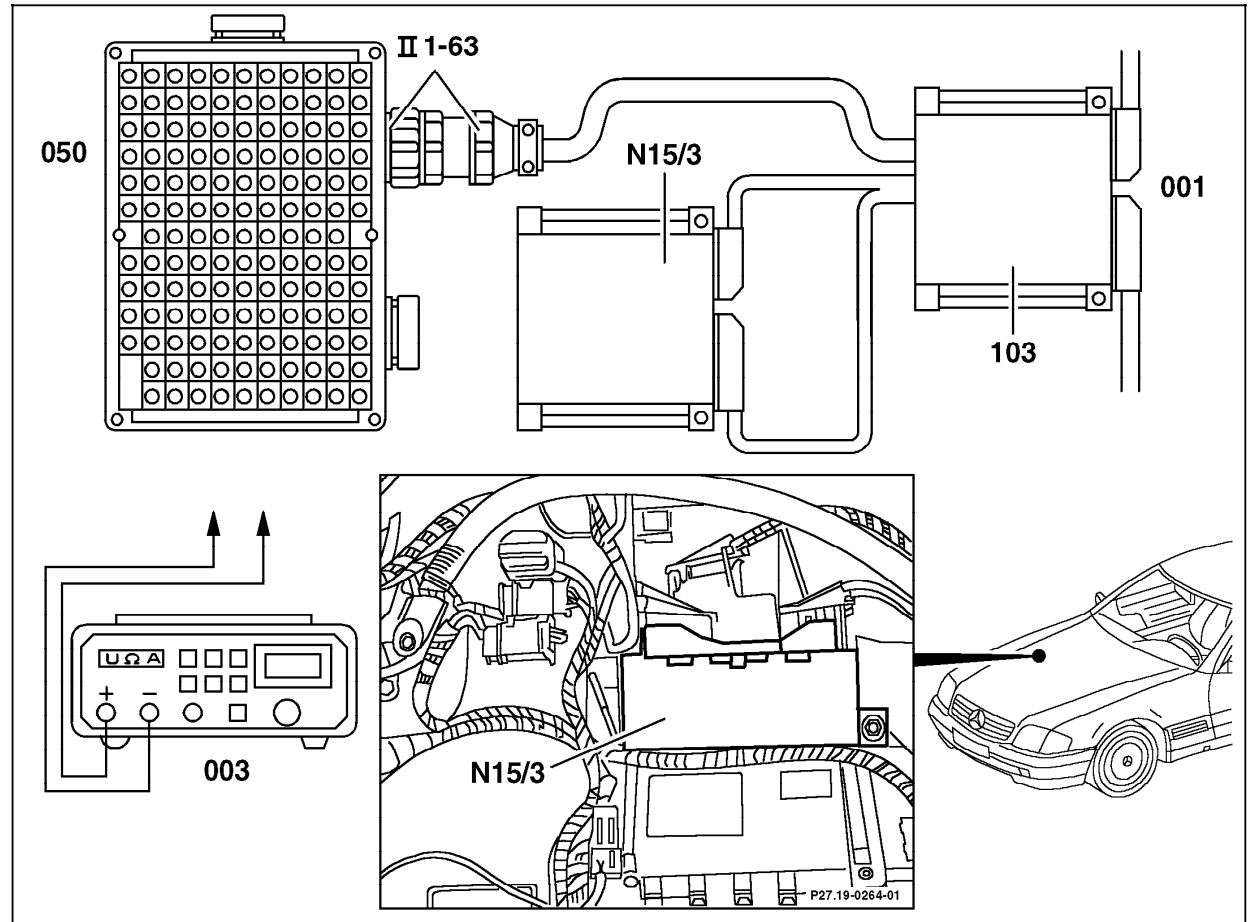

- 001 Connectors from control module
- 003 Multimeter
- 050 Socket box (126-pole)
- 103 Test cable
- N15/3 ETC control module (passenger side footwell)
- II 1-63 Socket positions 1-63

P27.19-0268-06



### Electrical Test Program – Preparation for Test

#### Connection Diagram – Socket Box Model 140

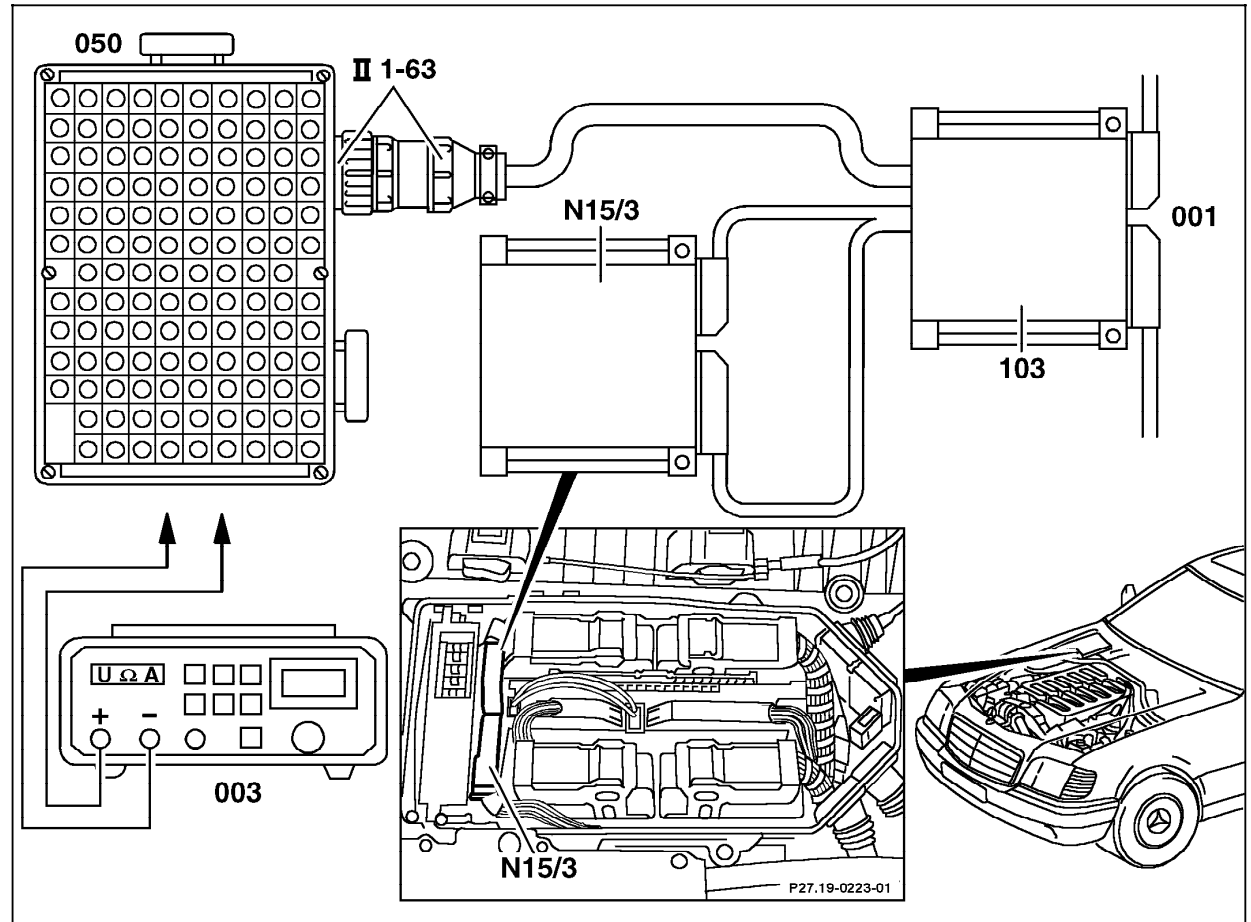

- 001 Connectors from control module
- 003 Multimeter
- 050 Socket box (126-pole)
- 103 Test cable
- N15/3 ETC control module
- II 1-63 Socket positions 1-63

P27.19-0302-06

### Electrical Test Program – Preparation for Test

#### Connection Diagram – Socket Box Model 163

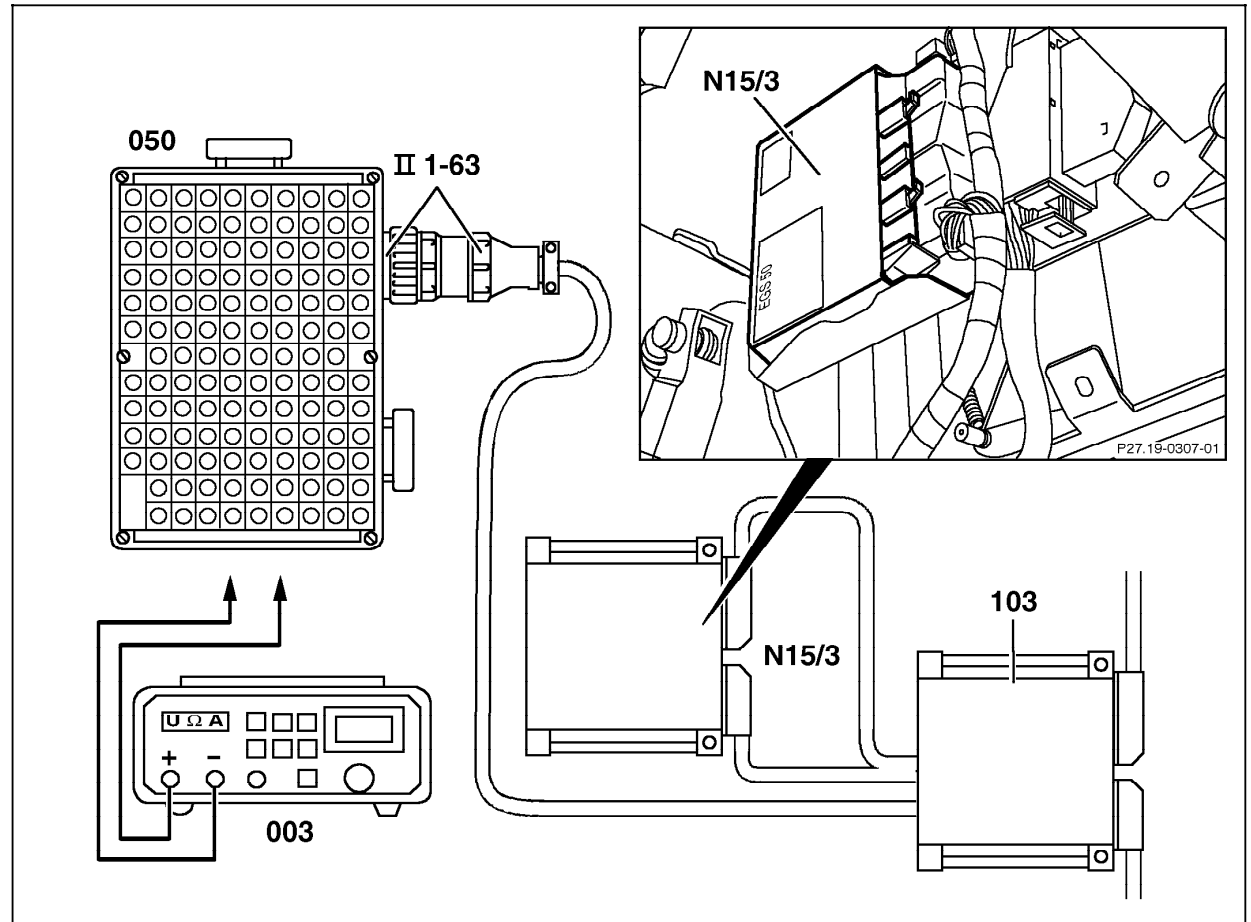

- 001 Connectors from control module
- 003 Multimeter
- 050 Socket box (126-pole)
- 103 Test cable
- N15/3 ETC control module
- II 1-63 Socket positions 1-63

P27.19-0306-06

Electrical Test Program – Preparation for Test

Connection Diagram – Socket Box  
Model 170

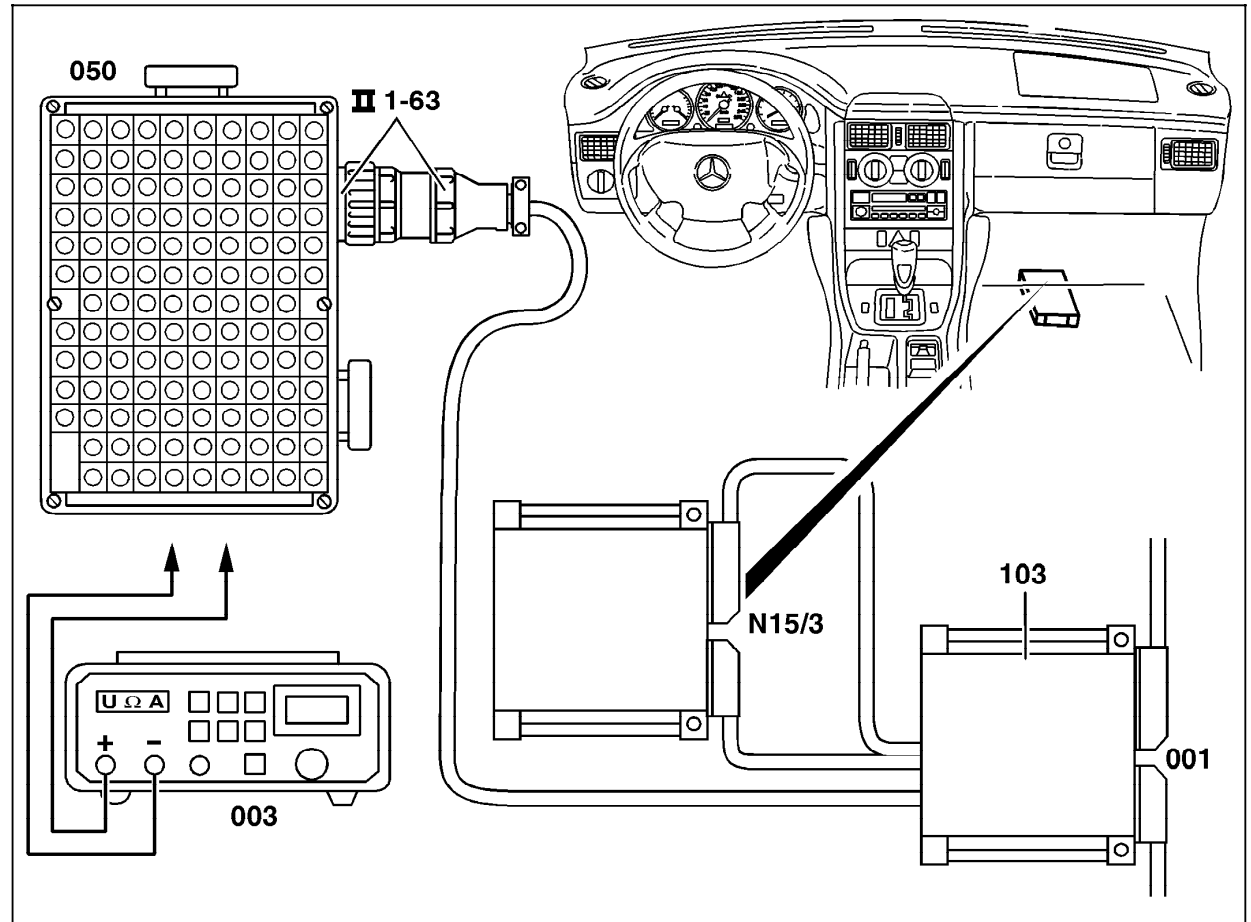

- 001 Connectors from control module
- 003 Multimeter
- 050 Socket box (126-pole)
- 103 Test cable
- N15/3 ETC control module
- II 1-63 Socket positions 1-63

P27.19-0271-06

### Electrical Test Program – Preparation for Test

Connection Diagram – Socket Box  
Models 202, 208

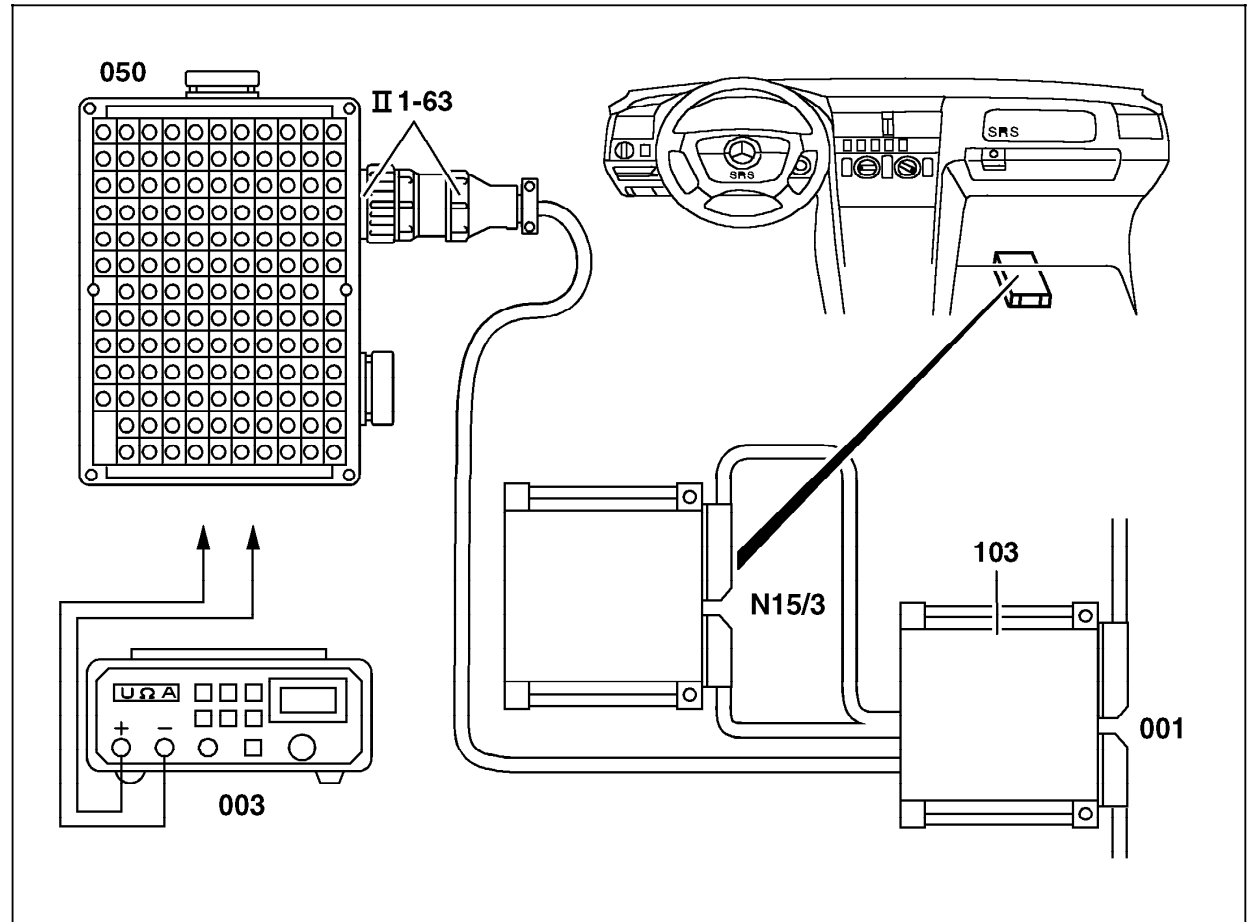

- 001 Connectors from control module
- 003 Multimeter
- 050 Socket box (126-pole)
- 103 Test cable
- N15/3 ETC control module
- II 1-63 Socket positions 1-63

P27.19-0273-06

### Electrical Test Program – Preparation for Test

#### Connection Diagram – Socket Box Model 210

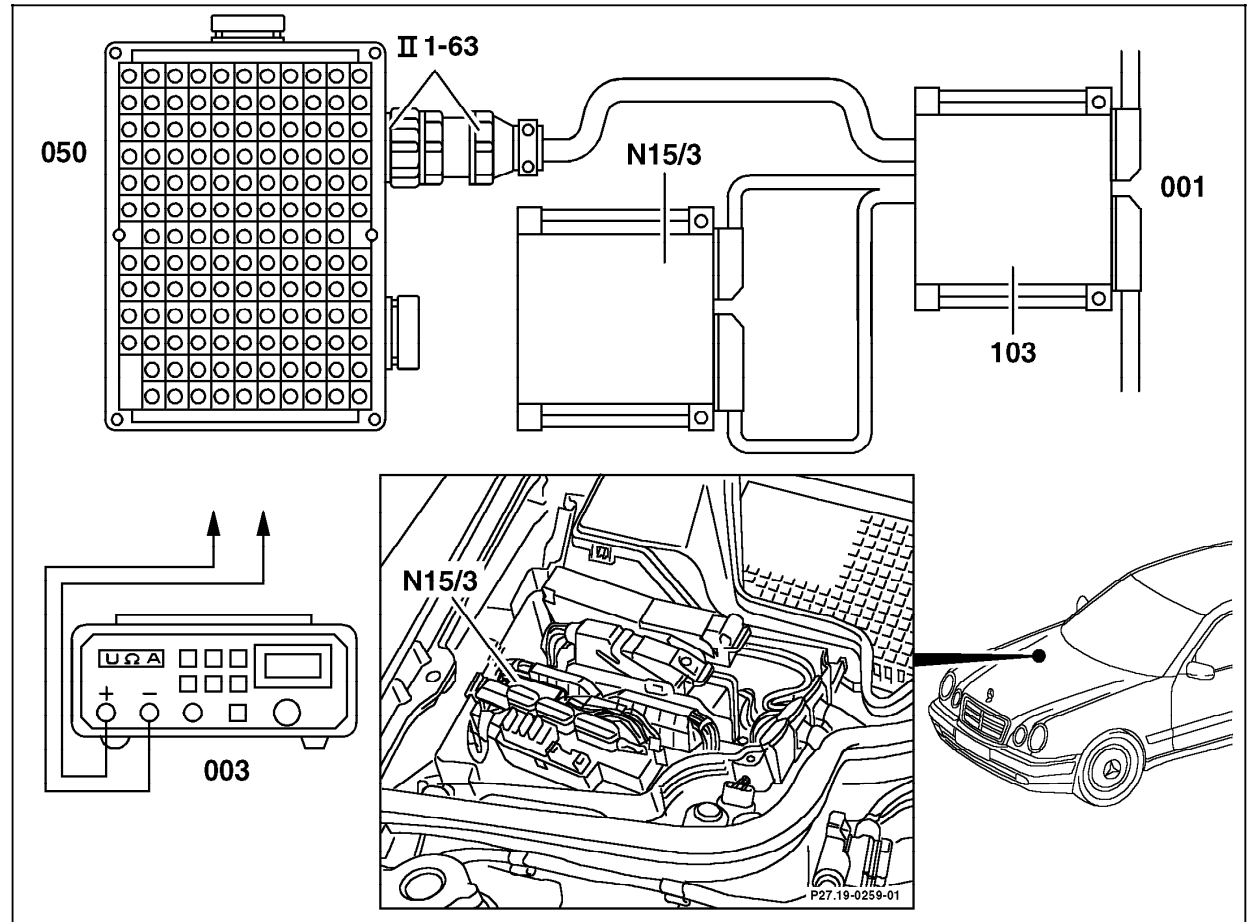





- 001 Connectors from control module
- 003 Multimeter
- 050 Socket box (126-pole)
- 103 Test cable
- N15/3 ETC control module
- II 1-63 Socket positions 1-63

P27.19-0263-06



### Electrical Test Program – Test

⇒		Test scope	Test connection	Test condition	Nominal value	Possible cause/Remedy
1.0		<b>ETC Control Module (N15/3)</b> Voltage supply Circuit 87	N15/3  30 —(V)— 29	Ignition: <b>ON</b>	11 – 14 V	Wiring, Base module, DM, Chassis and Drivetrain, section 1.1 or 1.2
2.0		<b>Diagnosis output</b>	N15/3  30 —(V)— 1	Ignition: <b>ON</b>	8 – 14 V	Wiring, N15/3
3.0		<b>Solenoid valves</b> Voltage supply	N15/3  30 —(V)— 38	Ignition: <b>ON</b>	11 – 14 V	23⇒ 1.0, Electrical conductor plate, ETC control module (N15/3)
4.0		<b>1-2/4-5 shift solenoid valve (Y3/6y3)</b> Internal resistance	N15/3  14 —(Ω)— 38	Disconnect ETC control module (N15/3). Ignition: <b>OFF</b>	2.5 – 6.5 Ω	Wiring, Y3/6y3
5.0		<b>2-3 shift solenoid valve (Y3/6y5)</b> Internal resistance	N15/3  16 —(Ω)— 38	Disconnect N15/3 Ignition: <b>OFF</b>	2.5 – 6.5 Ω	Wiring, Y3/6y5

### Electrical Test Program – Test



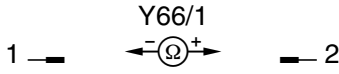

⇒		Test scope	Test connection	Test condition	Nominal value	Possible cause/Remedy
6.0	004	<b>3-4 shift solenoid valve (Y3/6y4)</b> Internal resistance	N15/3  15 —Ω— 38	Disconnect N15/3 Ignition: <b>OFF</b>	2.5 – 6.5 Ω	Wiring, Y3/6y4
7.0	005	<b>PWM solenoid valve (Y3/6y6)</b> Internal resistance	N15/3  17 —Ω— 38	Disconnect N15/3 Ignition: <b>OFF</b>	2 – 4 Ω	Wiring, Y3/6y6
8.0	006	<b>Modulator pressure regulating solenoid valve (Y3/6y1)</b> Internal resistance	N15/3  36 —Ω— 38	Disconnect N15/3 Ignition: <b>OFF</b>	4 – 8 Ω	Wiring, Y3/6y1
9.0	007	<b>Shift pressure regulating solenoid valve (Y3/6/2)</b> Internal resistance	N15/3  37 —Ω— 38	Disconnect N15/3 Ignition: <b>OFF</b>	4 – 8 Ω	Wiring, Y3/6y2

Electrical Test Program – Test





⇒		Test scope	Test connection	Test condition	Nominal value	Possible cause/Remedy
10.0		<p><b>R/P lock solenoid (Y66/1)</b> Internal resistance</p> <p><b>Note:</b> Test step applies to: 722.6 up to 6/30/99 in Models 202, 208, 210 without touch shift. 722.6 in Models 129, 140, 163 without touch shift. 722.602/605 in Model 170 without touch shift.</p>	<p>Y66/1</p> 	Test directly at Y66/1	20 – 35 Ω	Y66/1



Electrical Test Program – Test

⇒		Test scope	Test connection	Test condition	Nominal value	Possible cause/Remedy
11.0		<p><b>Starter lock-out relay module (K38/3)</b> Internal resistance</p> <p><b>Note:</b> Test step applies to: 722.6 in Model 129 with engine 104, 112. 722.6 in Model 140 with engine 104, 606. 722.6 in Model 170 up to 6/30/99 with engine 111. 722.6 in Model 202 up to 6/30/99 with engine 104, 111, 112. 722.6 in Model 208 up to 6/30/99 with engine 112. 722.6 in Model 210 up to 6/30/99 with engine 104, 112, 606</p>	<p style="text-align: center;">K38/3</p> <p style="text-align: center;">85 —  — 86</p>	Test directly at K38/3	50 Ω	K38/3
12.0		<p><b>RPM sensors</b> Voltage supply</p>	<p style="text-align: center;">N15/3</p> <p style="text-align: center;">33 —  — 13</p>	Ignition: <b>ON</b>	4 – 8 V	Wiring, Electrical conductor plate, N15/3

Electrical Test Program – Test

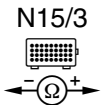
⇒		Test scope	Test connection	Test condition	Nominal value	Possible cause/Remedy
13.0		<p><b>Starter lock-out contact (Y3/6s1)</b> Function</p> <p><b>Note:</b> Test step applies to: 722.6 up to 6/30/99 in Models 202, 208, 210 without touch shift. 722.6 in Models 129, 140, 163 without touch shift. 722.602/605 in Model 170 without touch shift.</p>	<p>N15/3</p>  <p>34 —⌋ —⌋ 33</p>	<p>Disconnect N15/3</p> <p>R/D/4/3/2/1 selected</p> <p>P/N selected</p>	<p>0.5 – 2.5 kΩ</p> <p>&gt;20 kΩ</p>	<p>Wiring, Adjustment of shift linkage, Starter lock-out contact (Y3/6s1), Electrical conductor plate, Transmission range recognition switch (S16/10).</p>
14.0		<p><b>Starter lock-out contact (Y6/6s1)</b> Function</p> <p><b>Note:</b> Test step applies to: 722.6 as of 7/01/99 in Models 202, 208, 210 with touch shift. 722.6 in Model 163 with touch shift. 722.616/618 in Model 170 with touch shift.</p>	<p>N15/3</p>  <p>34 —⌋ —⌋ 33</p>	<p>Disconnect N15/3</p> <p>R/D/4/3/2/1 selected</p> <p>P/N selected</p>	<p>0.5 – 2.5 kΩ</p> <p>&gt;20 kΩ</p>	<p>Wiring, Adjustment of shift linkage, Starter lock-out contact (Y6/6s1), Electrical conductor plate.</p>

Electrical Test Program – Test

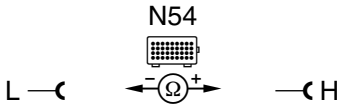
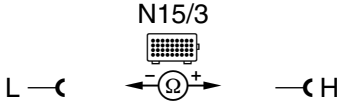
⇒		Test scope	Test connection	Test condition	Nominal value	Possible cause/Remedy
15.0		<b>CAN element in RCL control module (N54)</b> Resistance		Disconnect 2-pole connector at N54 and test directly at control module.	115 – 125 Ω	N54
16.0		<b>CAN element in ETC control module (N15/3)</b> Resistance		Disconnect 14-pole connector at N15/3 and test directly at control module.	50 – 100 Ω	N15/3

### Electrical Test Program – Test

#### Connector Layout - ETC control module (N15/3), applies to:

722.6 up to 6/30/99 in Models 202, 208, 210 without touch shift.

722.6 in Models 129, 140, 163 without touch shift.

722.602/605 in Model 170 without touch shift.

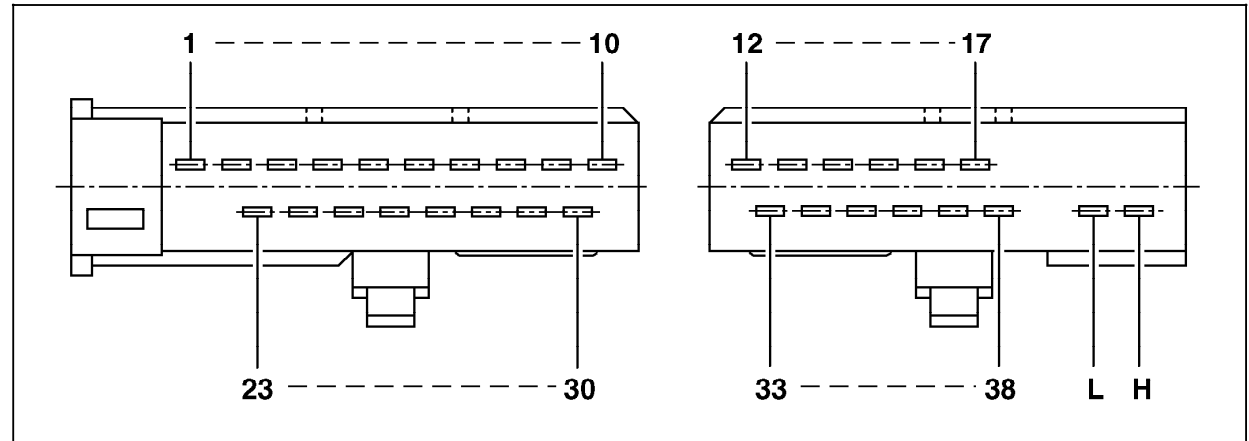

P27.19-0301-04

1	Diagnosis (output)	13	Sensor voltage supply	34	Valve unit, temperature sensor (Y3/6b1) / Starter lock-out contact (Y3/6s1)
2	Kickdown switch (S16/6)	14	Valve unit, 1-2/4-5 shift solenoid valve (Y3/6y3)	35	Valve unit, RPM sensor 3 (Y3/6n3)
3	W/S program switch (S16/10s2) (not in Model 163)	15	Valve unit, 3-4 shift solenoid valve (Y3/6y4)	36	Valve unit, modulator pressure regulating solenoid valve (Y3/6y1)
4	R/P lock solenoid (Y66/1)	16	Valve unit, 2-3 shift solenoid valve (Y3/6y5)	37	Valve unit, shift pressure regulating solenoid valve (Y3/6y2)
5-6	–	17	PWM solenoid valve (torque converter lock-up) (Y3/6y6)	38	Solenoid valves (Y3/6y1- y6), voltage supply
7	P/N signal to engine control module	23-24	–	L	CAN data line (-) (Low)
8	–	25-28	Transmission range recognition switch (S16/10) (voltage coded)	H	CAN data line (+) (High)
9	Brake lamp switch (S9/1) (in Model 210)	29	ETC control module (N15/3) (voltage supply)		
10	–	30	Ground (electronic output ground) (W15)		
12	RPM sensor 2 (Y3/6n2)	33	Sensor ground		

### Electrical Test Program – Test

#### Connector Layout - ETC control module (N15/3), applies to:

722.6 as of 7/01/99 in Models 202, 208, 210 with touch shift.

722.6 in Model 163 with touch shift.

722.616/618 in Model 170 with touch shift.

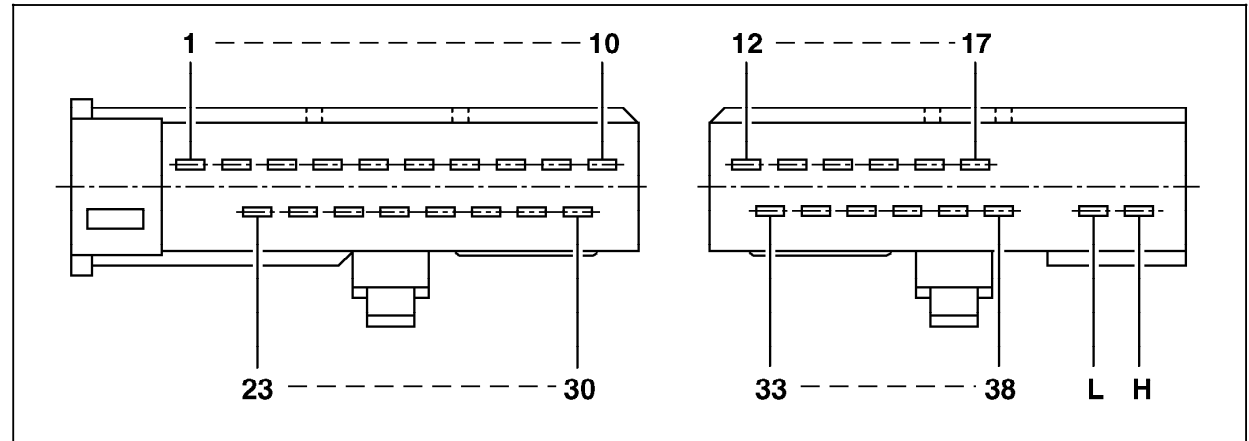

P27.19-0301-04

1	Diagnosis (output)	30	Ground (electronic output ground) (W15)	L	CAN data line (-) (Low)
2-10	-	33	Sensor ground	H	CAN data line (+) (High)
12	RPM sensor 2 (Y3/6n2)	34	Temperature sensor (Y3/6b1) / Starter lock-out contact (Y3/6s1)		
13	Sensor voltage supply	35	RPM sensor 3 (Y3/6n3)		
14	Valve unit, 1-2/4-5 shift solenoid valve (Y3/6y3)	36	Modulator pressure regulating solenoid valve (Y3/6y1)		
15	Valve unit, 3-4 shift solenoid valve (Y3/6y4)	37	Shift pressure regulating solenoid valve (Y3/6y2)		
16	Valve unit, 2-3 shift solenoid valve (Y3/6y5)	38	Solenoid valves (Y3/6y1- y6), voltage supply		
17	PWM solenoid valve (torque converter lock-up) (Y3/6y6)				
23-28	-				
29	ETC control module (N15/3) (voltage supply)				

### Electrical Test Program – Test

#### Connector Layout - 13 position round connector at transmission

- |    |  |
|----|--|
| 1  | RPM sensor 3 (Y3/6n3)  |
| 2  | Modulating pressure regulating solenoid valve (Y3/6y1)                       |
| 3  | RPM sensor 2 (Y3/6n2)  |
| 4  | Signal in: temperature sensor (Y3/6b1) and starter lock-out contact (Y3/6s1) |
| 5  | –  |
| 6  | Solenoid valves voltage supply   |
| 7  | Sensor voltage supply  |
| 8  | 2-3 shift solenoid valve (Y3/6y5)  |
| 9  | 3-4 shift solenoid valve (Y3/6y4)  |
| 10 | Shift pressure regulating solenoid valve (Y3/6y2)                            |
| 11 | PWM solenoid valve (torque converter lock-up) (Y3/6y6)                       |
| 12 | Sensor ground  |
| 13 | 1-2/4-5 shift solenoid valve (Y3/6y3)  |

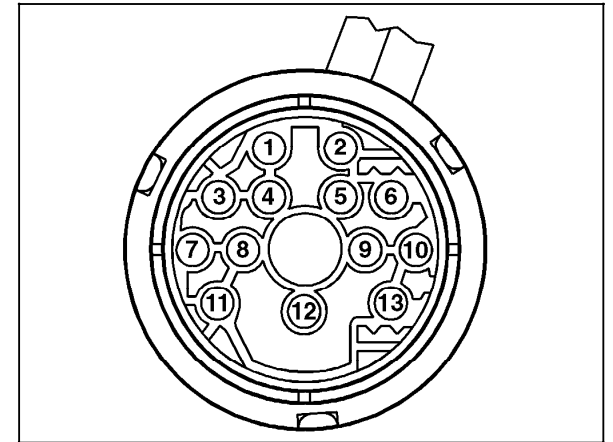

P27.19-0276-01