

Sales designation
Assortment class
Market
Picture number

E420
Car
North America
B54080000102.950518

Major assembly MD
Group
Subgroup

54 - ELECTRICAL EQUIPMENT AND INSTRUMENTS
080 - APPARATUS CASE AND CONTROL UNITS



56

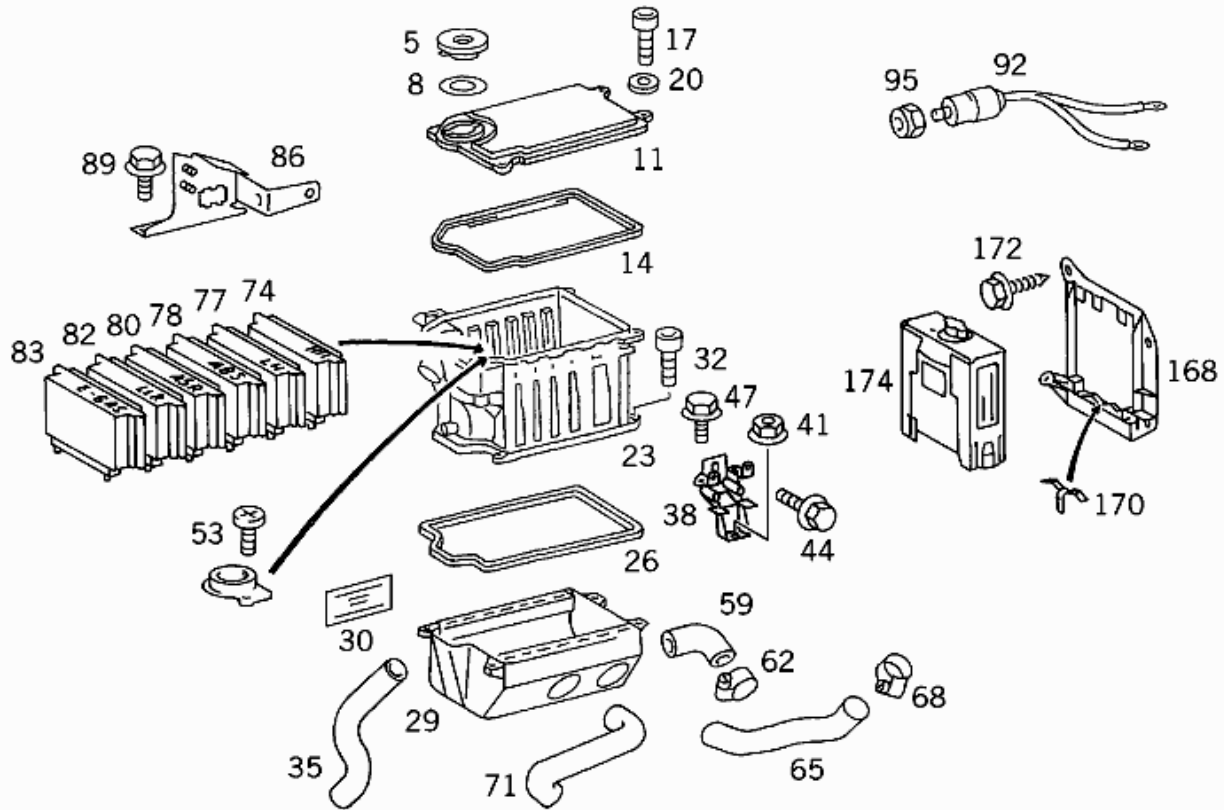

Item no.	Part number	Designation/description	Quantity	Version
5	A 000 540 03 82	COVER	001	
8	A 102 018 00 80	GASKET	001	
11	A 124 545 01 03	CAP APPARATUS CASE	001	
14	A 124 545 02 80	GASKET	001	
17	N 000912 006040	SCREW COVER TO APPARATUS CASE	004	
17	N 000912 006040	SCREW APPARATUS CASE TO BRACKET	002	
20	N 000125 006449	WASHER COVER TO APPARATUS CASE	004	
20	N 000125 006449	WASHER APPARATUS CASE TO BRACKET	002	
23	A 124 540 01 24	MODULE BOX APPARATUS CASE	001	
26	A 124 545 03 80	GASKET	001	
29	A 124 540 01 67	CABLE TRAY	001	
30	A 124 584 65 17	. GUIDE SIGN	001	
32	N 000912 005043	SCREW CABLE TRAY TO APPARATUS CASE	004	
35	A 124 997 77 82	HOSE MODULE BOX DRAIN	001	
38	A 124 542 31 40	BRACKET APPARATUS CASE	001	
41	N 913019 006002	NUT BRACKET TO CHASSIS	001	
44	N 914140 006006	SCREW APPARATUS CASE TO BRACKET	004	
47	N 914007 006013	COMBINATION BOLT GROUND TO MODULE BOX BRACKET	001	
53	N 007985 005504	SCREW DIAGNOSIS BOX	002	
56	A 004 997 59 90	LOOM TIE	002	
59	A 124 542 00 83	HOSE FROM BODY TO BLOWER	001	
62	A 006 997 43 90	LOOM TIE FROM BODY TO BLOWER	002	
65	A 124 542 01 83	HOSE FROM BLOWER TO MODULE BOX	001	
68	A 006 997 04 90	LOOM TIE FROM BLOWER TO MODULE BOX	002	
68	A 006 997 04 90	LOOM TIE FROM MODULE BOX TO BODY	002	
71	A 124 542 03 83	HOSE FROM MODULE BOX TO BODY	001	
74	A 011 545 97 32	BASIC MODULE	001	
77	A 014 545 15 32	MSG CONTROL UNIT [697, 821] PART IS ONLY OR ALSO SUPPLIED AS RECONDITIONED PART	001	
77	A 021 545 70 32	MSG CONTROL UNIT [697, 830] PART IS ONLY OR ALSO SUPPLIED AS RECONDITIONED PART	001	
78	A 013 545 94 32	ABS CONTROL UNIT	001	
80	A 013 545 39 32	ASR CONTROL UNIT	001	

82	A 124 545 36 32	CONTROL UNIT CRUISE/IDLING CONTROL	001
83	A 124 545 40 32	CONTROL UNIT E-GAS <input type="checkbox"/> [002, 093] ONLY FOR CANADA AND MEXICO	001
83	A 124 545 40 32	CONTROL UNIT E-GAS <input type="checkbox"/> [003] NOT FOR CANADA AND MEXICO	001
86	A 124 540 39 73	BRACKET	001
89	N 914128 005200	SHEET METAL SCREW	002
92	A 001 156 88 01	CONDENSER	001
95	N 913011 008000	NUT CONDENSER	001
168	A 124 540 46 73	BRACKET ELECTRONIC CONTROL BOX DIAGNOSE <input type="checkbox"/> [004, 821] CALIFORNIA	001
168	A 129 540 31 73	BRACKET ELECTRONIC CONTROL BOX DIAGNOSE <input type="checkbox"/> [004, 830] CALIFORNIA	001
168	A 129 540 31 73	BRACKET ELECTRONIC CONTROL BOX DIAGNOSE <input type="checkbox"/> [005, 840] FEDERAL AND CANADA AND MEXICO ONLY	001
170	A 000 545 12 97	. SPRING	002
172	N 914128 004303	SHEET METAL SCREW BRACKET TO STAY	NB
174	A 015 545 13 32	CONTROL UNIT DIAGNOSIS <input type="checkbox"/> [004] CALIFORNIA	001
174	A 015 545 13 32	CONTROL UNIT DIAGNOSIS <input type="checkbox"/> [005, 840] FEDERAL AND CANADA AND MEXICO ONLY	001