

MODEL 210.2

- 1 Bolt
2 Tailgate

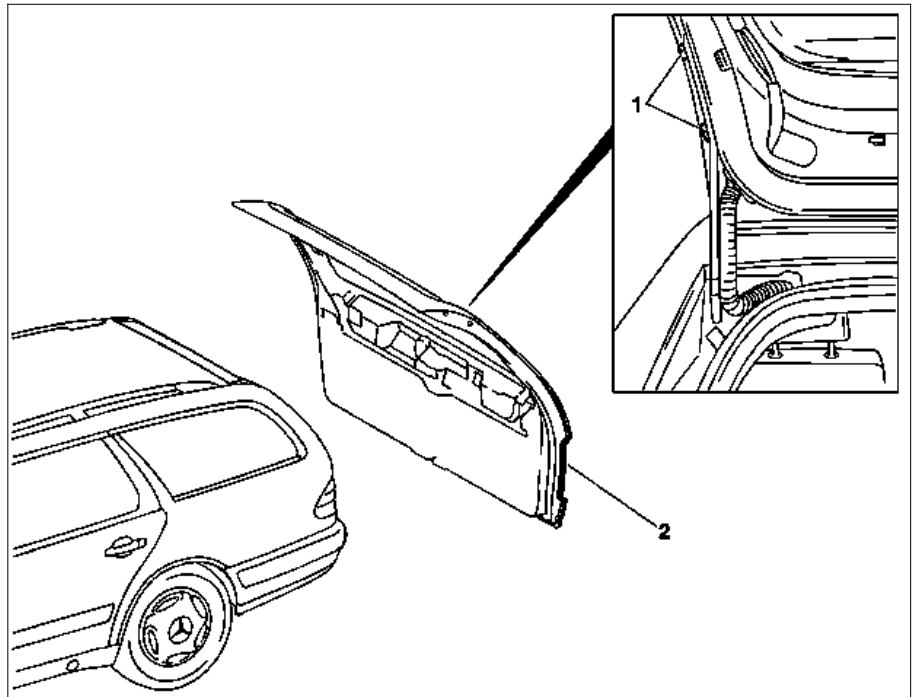

P72.20-0234-06

	Removing, installing		
1	Removing and installing tailgate liner		AR68.30-P-1050B
2	Disconnect or unbolt connections from tailgate, and pull out through cable guide		
3	Disconnect leads for windshield washing unit from wiper motor and pull out of tailgate		
4	Detach vacuum line from vacuum element and pull out of tailgate		
5	Mark installation position of hinge on tailgate		
6	Unscrew bolts (1) and remove tailgate (2) with helper		*BA72.20-P-1004-02A
7	Install in the reverse order		
8	Adjust tailgate		AR72.20-P-3510B

Tailgate



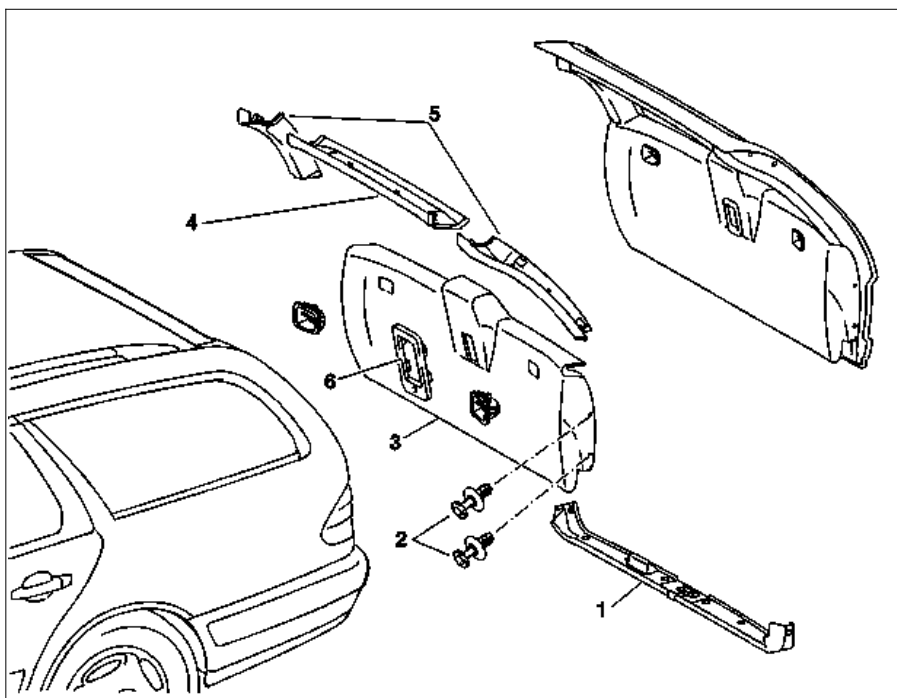

Number	Designation	Model 210.2
BA72.20-P-1004-02A	Bolts securing hinge assembly to tailgate	Nm 28

MODEL 210.2

- 1 Bottom panel
- 2 Plastic clip
- 3 Cover
- 4 Top panel
- 5 Left and right panels
- 6 Interior lock release frame



P68.30-0324-06

 	Removal, installation		
1	Remove bottom panel (1)		
2	Remove frame (6) for interior lock release		
3	Remove plastic clip (2)		
4	Remove panel (3)	 Slide panel upward and remove	
6	Unhook top panel (4) with long wedge and remove		*115589035900
7	Unhook left and right panels (5) with long wedge and press off toward inside of door		*115589035900
8	Reinstall in opposite order		

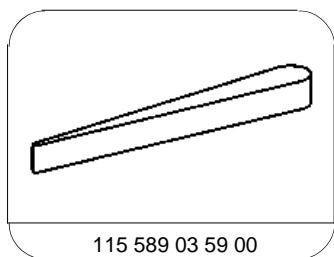

115 589 03 59 00



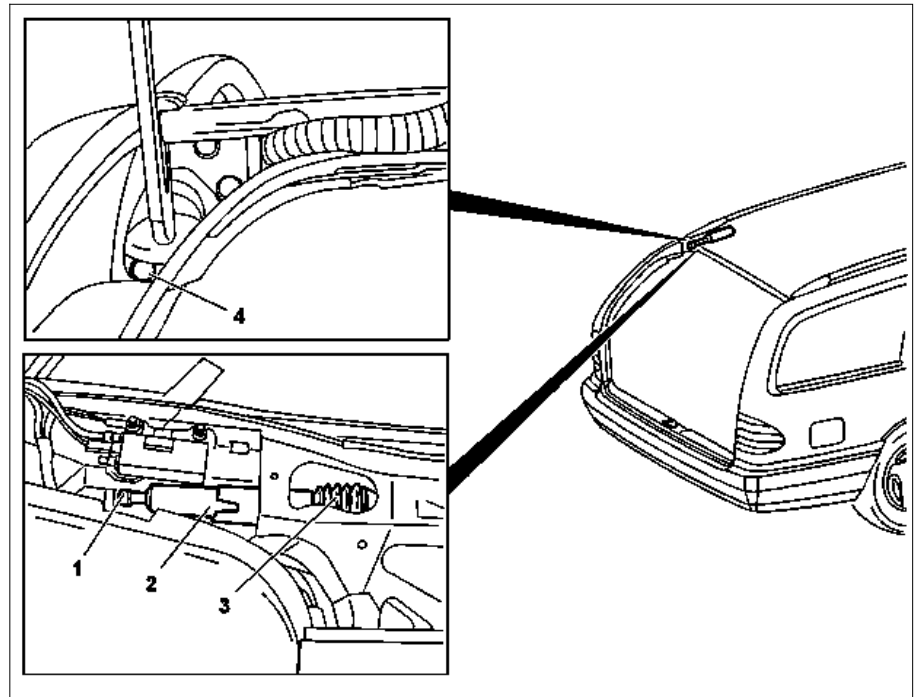

Long wedge

MODEL 210.2

- 1 Front ball head
- 2 Gas pressure strut
- 3 Protective sleeve
- 4 Rear ball head



P72.20-0232-06

 	Removal, installation		
1	Remove rear roof frame paneling		AR68.30-P-4470A
2	Secure tailgate with support		
3	Lift retainer on front ball head (1)	 Do not remove retainer, otherwise tension is lost	
4	Lift retainer on rear ball head (4)	 Do not remove retainer, otherwise tension is lost	
5	Remove gas pressure strut (2) together with protective sleeve (3)	 When replacing gas pressure strut ↓ Dispose of gas pressure strut (old part)	OS00.00-P-1001-01A
6	Reinstall in opposite order		

MODELS 202.07 /08 /18, 210.2

Model 202

- 1 Center roof frame covering
- 2 Side roof frame covering
- 3 Mount for double sun shade
- 4 Rear courtesy light

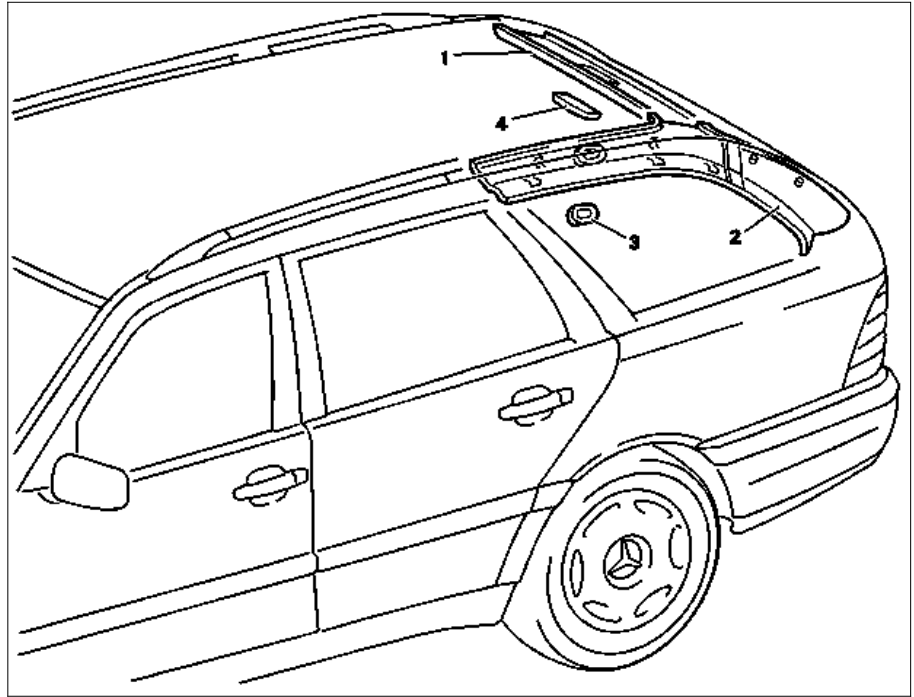

P68.30-0270-06

Model 210

- 1 Center roof frame covering
- 2 Side roof frame covering
- 3 Mount for double sun shade
- 4 Rear courtesy light

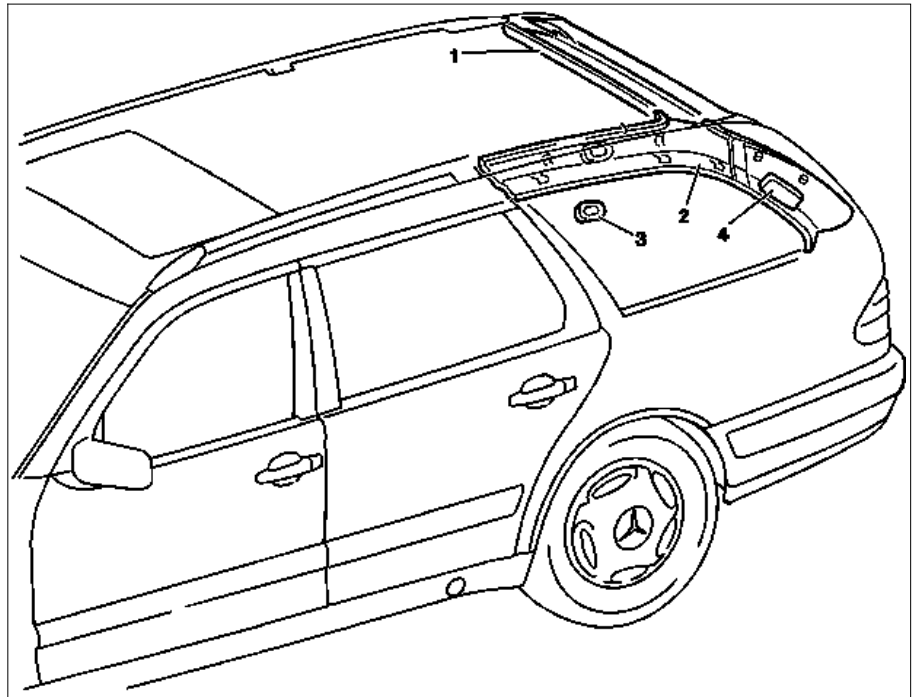

P68.30-0303-06

☒ ☒	Removing, installing		
1	Remove paneling on C-pillar	Model 202 Model 210	AR68.30-P-4490EA AR68.30-P-4490FA
2	Remove mount for double sun shade (3)		
3	Unclip side roof frame cover (2) and pull out downward		
4	Pull out rear lamp (4) downward		
5	Unclip center roof frame cover (1) downward and pull out toward front		
6	Install in the reverse order	i Installation: Model 210.2 with folding bench storage compartment, opposite the direction of motion (Code 844) When replacing the roof frame trim openings must be made at the rear for the belt deflectors. Refer to: ↓	

		Stamping opening in trim of rear roof frame [i] Without windowbag (code 290)	AN68.30-P-4470-01FA
		Make opening in trim of rear roof frame [i] With windowbag (code 290)	AN68.30-P-4470-02FA

OS00.00-P-1001-01A ⚠ Danger!	Releasing gas from gas strut and emptying Risk of injury from drilling gas-filled subassemblies or components (gas filling non-combustible)	Wear safety glasses and face mask.	AS00.00-Z-0006-01A
--	---	------------------------------------	--------------------

1 Clamp gas-operated strut in machine vise of pillar drilling machine.

i Conrod must point away from body, no other persons must be within danger area.

2 Drill gas-operated strut approx. 20 mm (dimension a) from bottom of gas-operated strut \varnothing with a 3 mm drill (arrow). Drill with as little force as possible.

3 Unclamp gas-operated strut, pump gas-operated strut empty by pressing conrod in several times.

i Observe regulations for disposal of hydraulic oil.

4 Dispose of gas-operated strut (worn part).

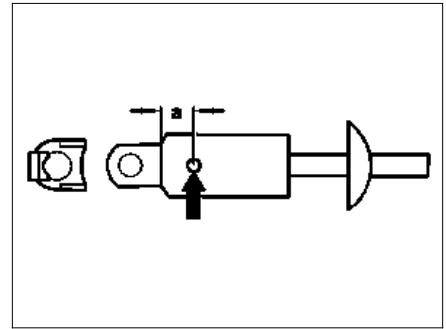

P88.40-0216-01