

18 Insert drive shaft (11) into the bearing flange (4). After this, fit rotor (7) with the chamfer on the inner diameter facing the flange of the drive shaft.

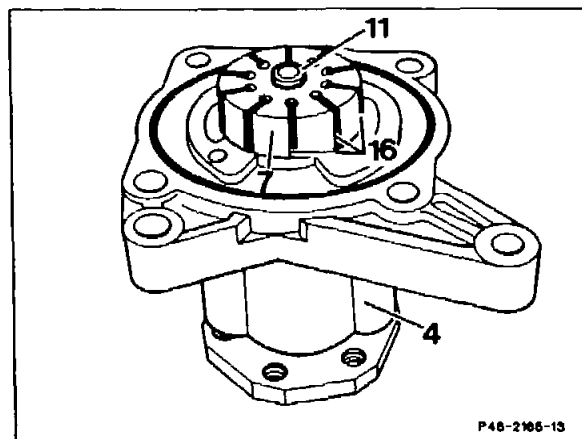

19 Fit new locking ring (18) onto the drive shaft. Ensure that the locking ring is correctly seated in the groove.

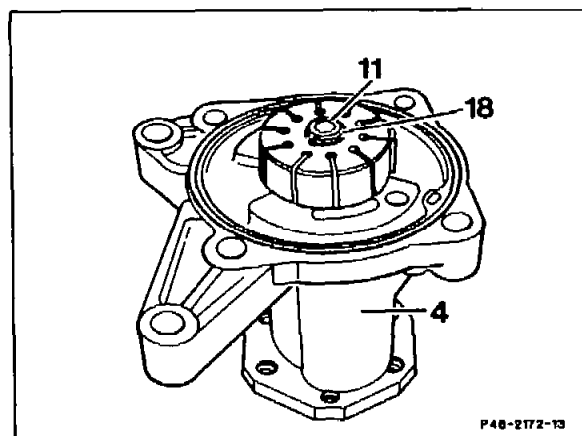

20 Insert the cam insert with the cast or stamped-in direction of rotation arrow (arrows) facing upwards into straight pins on the pump housing.

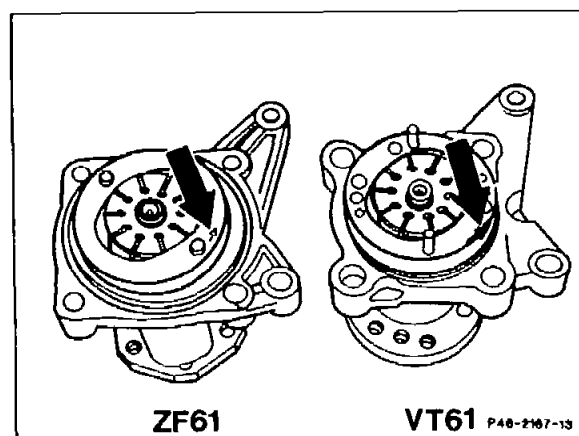

21 Insert vanes (10 off) into the rotor with the rounded, metallic glossy sides (arrow) facing the cam insert.

